



**Werkzeugaufnahmen  
ISO 12164 und DIN 69893**

***Toolholders  
ISO 12164 and DIN 69893***

**Porte-outils  
ISO 12164 et DIN 69893**

DISCOUNT  
**P&GE** 20%

**ISO 1184 - HSK**

**DIN 69893 - HSK**



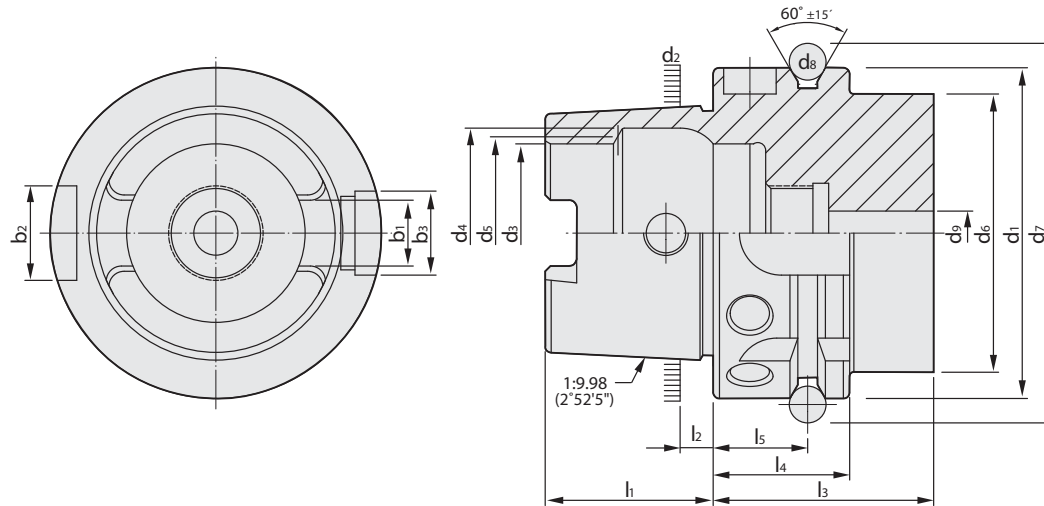

5

HSK	d <sub>1</sub> h10	d <sub>2</sub> H10	d <sub>3</sub> H10	d <sub>4</sub> H11	d <sub>5</sub>	d <sub>6</sub> max	d <sub>7</sub> 0 -0,1	d <sub>8</sub>	d <sub>9</sub> max	l <sub>1</sub> 0 -0,2	l <sub>2</sub>	l <sub>3</sub> min	l <sub>4</sub> 0 -0,1	l <sub>5</sub> ±0,1	b <sub>1</sub> ±0,04	b <sub>2</sub> H10	b <sub>3</sub> H10
25	25	19,006	14	16,4	15	20	28,5	3	3	13	2,5	20	10	4,5	6,05	6	7
32	32	24,007	17	20,5	19	26	37	4	4,2	16	3,2	35	20	16	7,05	7	9
40	40	30,007	21	25,5	23	34	45	4	5	20	4	35	20	16	8,05	9	11
50	50	38,009	26	32	29	42	59,3	7	6,8	25	5	42	26	18	10,54	12	14
63	63	48,010	34	40	37	53	72,3	7	8,4	32	6,3	42	26	18	12,54	16	18
80	80	60,012	42	50	46	68	88,8	7	10,2	40	8	42	26	18	16,04	18	20
100	100	75,013	53	63	58	88	109,75	7	12	50	10	45	29	20	20,02	20	22
125	125	95,016	67	80	73	111	134,75	7	14	63	12,5	45	29	20	25,02	25	28

**Vorgewuchtet G 6,3 15.000 min-1**Pre-balanced G 6,3 15.000 min-1  
Pré-équilibré G 6,3 15.000 min-1**G 2,5 Feinwuchten gegen Aufpreis**G 2.5 Fine balancing at extra charge  
G 2,5 Equilibrage fin contre un supplément**Werkstoff:** Legierter Einsatzstahl mit einer Zugfestigkeit im Kern von min. 950 N / mm<sup>2</sup>. Einsatzgehärtet HRC 60 ± 2 (HV 700 ± 50), Härtetiefe 0,8 mm ± 0,2 mm, brüniert und präzisionsgeschliffen.**Material:** Alloyed case-hardened steel, tensile core strength of min. 950 N / mm<sup>2</sup>. Case hardened HRC 60 ± 2 (HV 700 ± 50), hardening depth 0.8 mm ± 0.2 mm, black-finished and precisely grinded.**Matière:** Acier de cémentation allié. Résistance à la traction dans le noyau de min 950 N / mm<sup>2</sup>. Cémentation à HRC 60 ± 2 (HV 700 ± 50), profondeur de cémentation 0,8 mm ± 0,2 mm, bruni et rectifié précisément.**Normative Verweise:**ISO 12164-1:2023-10  
Hohlkegelschnittstelle mit Plananlage -  
Teil 1: Schäfer der Typen A, AB, C, CB und EBISO 12164-1:2001-12  
Hohlkegelschnittstelle mit Plananlage  
- Teil 1: Schäfer; MaßeDIN 69893-1:2011  
Kegel-Hohlschäfte mit Plananlage besteht aus:  
- Teil 1: Kegel-Hohlschäfte Form A und Form C;  
Maße und Ausführung**Normative references:**ISO 12164-1:2023-10  
Hollow taper interface with flange contact surface -  
Part 1: Shanks of types A, AB, C, CB and EBISO 12164-1:2001  
Hollow taper interface with flange contact surface  
- Part 1: Shanks; DimensionsDIN 69893-1:2011  
Hollow taper shanks with flange contact surface:  
- Part 1: Hollow taper shanks type A and type C;  
Dimensions and design**Références normatives:**ISO 12164-1:2023-10  
Interfaces à cône creux-face Partie 2: Nez de broches de type  
A, C et E pour queues à cône creux-face de type A, AB, C, CB et EBISO 12164-1:2001  
Interfaces à cône creux-face  
- Partie 1: Queues; DimensionsDIN 69893-1:2011  
Queues creuses coniques à surface de contact plane:  
- Partie 1: Queues creuses coniques type A et type C;  
Dimensions et conception



Index  
Sommaire

5.05	5.06	5.07	5.09
5.10	5.11	5.13	5.16
5.19	5.21	5.23	5.25
5.26	5.27	5.28	5.29
5.30	5.31	5.32	5.33
5.34	5.35	5.39	5.45
5.47	5.48	5.49	5.50-5.52
5.55	5.65	5.85	
HSK-E	HSK-F	HSK-T	



**Verwendung:**

Zur Aufnahme von Werkzeugen mit Zylinderschaft in Spannzangen.

**Application:**

For mounting straight-shank tools in collets.

**Application:**

Destiné à recevoir les outils avec les queues de forme cylindrique dans les pinces de serrage.

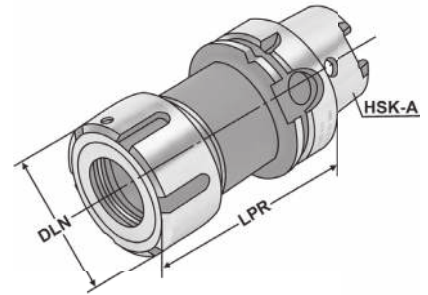

ISO 12164	Form A	$\leq 3\mu\text{m}$	G2,5 25.000 min <sup>-1</sup>	RFID Chip	ISO 10897
-----------	--------	---------------------	-------------------------------	-----------	-----------

**i**  
13.04

5

Bestell-Nr. Order no. Référence	HSK	DCONWS Spannbereich Capacity   Capacité	Typ	LPR	DLN	THID	EUR
A63.01.16	HSK-A 63	2 - 16	415E   OZ 16	100	43	M16 x 2,0	117,00
A63.01.25	HSK-A 63	2 - 25	462E   OZ 25	100	60	M16 x 2,0	117,00
A63.01.32	HSK-A 63	3 - 32	467E   OZ 32	120	72	M16 x 2,0	124,00
A100.01.16	HSK-A 100	2 - 16	415E   OZ 16	110	43	M16 x 2,0	149,00
A100.01.25	HSK-A 100	2 - 25	462E   OZ 25	120	60	M16 x 2,0	149,00
A100.01.32	HSK-A 100	3 - 32	467E   OZ 32	130	72	M16 x 2,0	159,00

**Lieferumfang:** Mit kugelgelagerter Spannmutter  
**Delivery:** With ball bearing clamping nut  
**Livraison:** Avec écrou de serrage à roulement à billes



Collet chucks for collets | KPS-system

Mandrins à pinces pour pinces | Système KPS

**Verwendung:**

Zur Aufnahme von Werkzeugen mit Zylinderschaft in Spannzangen.  
Für Anwendungen im HSC-Bereich und für hochpräzise Bearbeitungsergebnisse.

**Application:**

For mounting straight-shank tools in collets.  
To use for high speed cutting and high precision milling.

**Utilisation:**

Pour la fixation d'outils à queue cylindrique dans les pinces de serrage. Pour l'UGV (Usinage à Grande Vitesse) et pour des résultats d'usinage de haute précision.

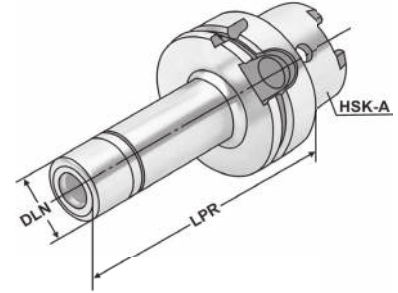

Bestell-Nr. Order no. Référence	HSK	DCONWS Spannbereich Capacity   Capacité	Typ	LPR	DLN	THID	EUR
A40.03.10	HSK-A 40	1 – 10	490EK   KPS 10	75	27,5	M12 x 1,75	130,00
A40.03.16	HSK-A 40	4 – 16	496EK   KPS 16	80	40,0	M18 x 1,50	135,00
A50.03.10	HSK-A 50	1 – 10	490EK   KPS 10	60	27,5	M12 x 1,75	130,00
A50.03.16	HSK-A 50	4 – 16	496EK   KPS 16	80	40,0	M18 x 1,50	135,00
A63.03.10	HSK-A 63	1 – 10	490EK   KPS 10	100	27,5	M12 x 1,75	147,00
A63.03.10.2	HSK-A 63	1 – 10	490EK   KPS 10	160	27,5	M12 x 1,75	209,00
A63.03.16	HSK-A 63	4 – 16	496EK   KPS 16	120	40,0	M18 x 1,50	155,00
A63.03.16.2	HSK-A 63	4 – 16	496EK   KPS 16	160	40,0	M18 x 1,50	209,00

5

**Lieferumfang:** Mit gewuchteter Spannmutter  
**Delivery:** With balanced clamping nut  
**Livraison:** Avec écrou de serrage équilibré

**Gewuchtete Ausführung**

Balanced type  
Type équilibré



Bestell-Nr. Order no. Référence	Ausführung Version Exécution
---------------------------------------	------------------------------------

**Wuchten auf G 2,5 von vorgewuchteten Kemmler-Werkzeugen**

Balancing at G 2.5 of pre-balanced Kemmler-tools  
Équilibrage G 2,5 d'outils Kemmler pré-équilibrés

W25 **Ohne Wuchtprotokoll**  
Without balancing report  
Sans protocole d'équilibrage

W25.2 **Mit Wuchtprotokoll**  
With balancing report  
Avec protocole d'équilibrage

Wuchten von nicht vorgewuchteten Werkzeugen  
Balancing of unbalanced tools  
Équilibrage d'outils non-équilibrés

W25.1 **Ohne Wuchtprotokoll**  
Without balancing report  
Sans protocole d'équilibrage



**Verwendung:**

Zur Aufnahme von Werkzeugen mit Zylinderschaft in Spannzangen.

**Application:**

For mounting straight-shank tools in collets.

**Application:**

Destiné à recevoir les outils avec les queues de forme cylindrique dans les pinces de serrage.

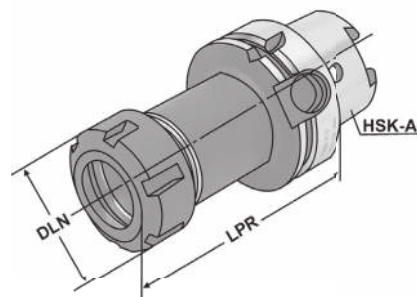
ISO  
12164Form  
ARFID  
ChipISO  
15488

13.04

5

Bestell-Nr. Order no. Référence	HSK	DCONWS Spannbereich Capacity   Capacité	Typ	LPR	DLN	THID	EUR
A32.02.10	HSK-A 32	1 - 10	426E   ER 16	80	32	M10 x 1,5	120,00
A32.02.20	HSK-A 32	2 - 20	470E   ER 32	85	50	M16 x 2,0	120,00
A40.02.10	HSK-A 40	1 - 10	426E   ER 16	80	32	M10 x 1,5	120,00
A40.02.16	HSK-A 40	2 - 16	430E   ER 25	80	42	M16 x 2,0	120,00
A40.02.20	HSK-A 40	2 - 20	470E   ER 32	80	50	M16 x 2,0	123,00
A50.02.10	HSK-A 50	1 - 10	426E   ER 16	100	32	M10 x 1,5	120,00
A50.02.16	HSK-A 50	2 - 16	430E   ER 25	80	42	M16 x 2,0	120,00
A50.02.20	HSK-A 50	2 - 20	470E   ER 32	100	50	M16 x 2,0	123,00
A63.02.10.0	HSK-A 63	1 - 10	426E   ER 16	75	32	-	102,00
A63.02.13.0	HSK-A 63	2 - 13	428E   ER 20	75	35	-	102,00
A63.02.16.0	HSK-A 63	2 - 16	430E   ER 25	75	42	-	102,00
A63.02.20.0	HSK-A 63	2 - 20	470E   ER 32	75	50	-	107,00
A63.02.26.0	HSK-A 63	3 - 26	472E   ER 40	85	63	-	114,00
A63.02.10	HSK-A 63	1 - 10	426E   ER 16	100	32	M10 x 1,5	102,00
A63.02.13	HSK-A 63	2 - 13	428E   ER 20	100	35	M12 x 1,75	102,00
A63.02.16	HSK-A 63	2 - 16	430E   ER 25	100	42	M16 x 2,0	102,00
A63.02.20	HSK-A 63	2 - 20	470E   ER 32	100	50	M16 x 2,0	107,00
A63.02.26	HSK-A 63	3 - 26	472E   ER 40	120	63	M16 x 2,0	114,00
A63.02.10.130	HSK-A 63	1 - 10	426E   ER 16	130	32	M10 x 1,5	126,00
A63.02.13.130	HSK-A 63	2 - 13	428E   ER 20	130	35	M12 x 1,75	126,00
A63.02.16.130	HSK-A 63	2 - 16	430E   ER 25	130	42	M16 x 2,0	133,00
A63.02.20.130	HSK-A 63	2 - 20	470E   ER 32	130	50	M16 x 2,0	136,00
A63.02.26.130	HSK-A 63	3 - 26	472E   ER 40	130	63	M16 x 2,0	142,00
A63.02.10.1	HSK-A 63	1 - 10	426E   ER 16	160	32	M10 x 1,5	151,00
A63.02.13.1	HSK-A 63	2 - 13	428E   ER 20	160	35	M12 x 1,75	151,00
A63.02.16.1	HSK-A 63	2 - 16	430E   ER 25	160	42	M16 x 2,0	151,00
A63.02.20.1	HSK-A 63	2 - 20	470E   ER 32	160	50	M16 x 2,0	155,00
A63.02.26.1	HSK-A 63	3 - 26	472E   ER 40	160	63	M16 x 2,0	167,00
A63.02.10.3	HSK-A 63	1 - 10	426E   ER 16	200	32	M10 x 1,5	198,00
A63.02.13.3	HSK-A 63	2 - 13	428E   ER 20	200	35	M12 x 1,75	198,00
A63.02.16.3	HSK-A 63	2 - 16	430E   ER 25	200	42	M16 x 2,0	198,00
A63.02.20.3	HSK-A 63	2 - 20	470E   ER 32	200	50	M16 x 2,0	198,00
A63.02.26.3	HSK-A 63	3 - 26	472E   ER 40	200	63	M16 x 2,0	209,00

Collet chucks for collets ISO 15488 (DIN 6499)  
Mandrins à pinces pour pinces ISO 15488 (DIN 6499) système ER

(DIN 69893-1 | HSK-A)



**Verwendung:**  
Zur Aufnahme von Werkzeugen mit  
Zylinderschaft in Spannzangen.

**Application:**  
For mounting straight-shank tools in  
collets.

**Application:**  
Destiné à recevoir les outils avec les  
queues de forme cylindrique dans les  
pinces de serrage.

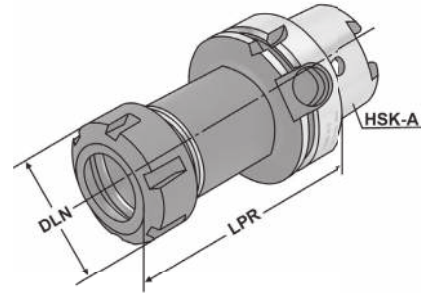

Bestell-Nr. Order no. Référence	HSK	DCONWS Spannbereich Capacity   Capacité	Typ	LPR	DLN	THID	EUR
A100.02.10	HSK-A 100	1 – 10	426E   ER 16	100	32	M10 x 1,5	130,00
A100.02.16	HSK-A 100	2 – 16	430E   ER 25	100	42	M16 x 2,0	130,00
A100.02.20	HSK-A 100	2 – 20	470E   ER 32	100	50	M16 x 2,0	130,00
A100.02.26	HSK-A 100	3 – 26	472E   ER 40	120	63	M16 x 2,0	135,00
A100.02.10.130	HSK-A 100	1 – 10	426E   ER 16	130	32	M10 x 1,5	199,00
A100.02.16.130	HSK-A 100	2 – 16	430E   ER 25	130	42	M16 x 2,0	199,00
A100.02.20.130	HSK-A 100	2 – 20	470E   ER 32	130	50	M16 x 2,0	199,00
A100.02.26.130	HSK-A 100	3 – 26	472E   ER 40	130	63	M16 x 2,0	199,00
A100.02.10.2	HSK-A 100	1 – 10	426E   ER 16	160	32	M10 x 1,5	167,00
A100.02.16.2	HSK-A 100	2 – 16	430E   ER 25	160	42	M16 x 2,0	167,00
A100.02.20.2	HSK-A 100	2 – 20	470E   ER 32	160	50	M16 x 2,0	167,00
A100.02.26.2	HSK-A 100	3 – 26	472E   ER 40	160	63	M16 x 2,0	167,00
A100.02.10.3	HSK-A 100	1 – 10	426E   ER 16	200	32	M10 x 1,5	284,00
A100.02.16.3	HSK-A 100	2 – 16	430E   ER 25	200	42	M16 x 2,0	284,00
A100.02.20.3	HSK-A 100	2 – 20	470E   ER 32	200	50	M16 x 2,0	293,00
A100.02.26.3	HSK-A 100	3 – 26	472E   ER 40	200	63	M16 x 2,0	312,00

**Lieferumfang:** Mit gewuchteter Spannmutter

**Delivery:** With balanced clamping nut

**Livraison:** Avec écrou de serrage équilibré

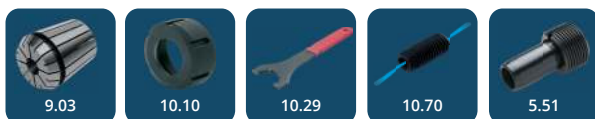

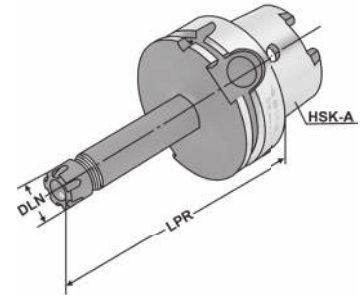

**Verwendung:**Zur Aufnahme von Werkzeugen mit  
Zylinderschaft in Spannzangen.**Application:**For mounting straight-shank tools in  
collets.**Application:**Destiné à recevoir les outils avec les  
queues de forme cylindrique dans les  
pinces de serrage.

5

Bestell-Nr. Order no. Référence	HSK	DCONWS Spannbereich Capacity   Capacité	Typ	LPR	DLN	THID	EUR
A32.02.07.M	HSK-A 32	1 - 7	4008E   ER 11	50	16	M5	120,00
A32.02.10.M	HSK-A 32	1 - 10	426E   ER 16	50	22	-	125,00
A32.02.16.M	HSK-A 32	2 - 16	430E   ER 25	80	35	M8	130,00
A40.02.07.M	HSK-A 40	1 - 7	4008E   ER 11	40	16	-	125,00
A40.02.10.M	HSK-A 40	1 - 10	426E   ER 16	80	22	M8	130,00
A50.02.07.M	HSK-A 50	1 - 7	4008E   ER 11	60	16	M6	130,00
A50.02.10.M	HSK-A 50	1 - 10	426E   ER 16	60	22	-	135,00
A63.02.07.1	HSK-A 63	1 - 7	4008E   ER 11	100	16	M8 x 1,25	163,00
A63.02.07.2	HSK-A 63	1 - 7	4008E   ER 11	160	16	M8 x 1,25	186,00
A63.02.07.10.1	HSK-A 63	1 - 10	426E   ER 16	100	22	7/16" 20 UNF	163,00
A63.02.07.10.2	HSK-A 63	1 - 10	426E   ER 16	160	22	7/16" 20 UNF	186,00
A63.02.07.13.1	HSK-A 63	1 - 13	428E   ER 20	100	28	9/16" 18 UNF	163,00
A63.02.07.13.2	HSK-A 63	1 - 13	428E   ER 20	160	28	9/16" 18 UNF	186,00
A63.02.07.16.1	HSK-A 63	2 - 16	430E   ER 25	100	35	11/16" 16 UN	163,00
A63.02.07.16.2	HSK-A 63	2 - 16	430E   ER 25	160	35	11/16" 16 UN	186,00
A100.02.07.1	HSK-A 100	1 - 7	4008E   ER 11	100	16	M8 x 1,25	218,00
A100.02.07.2	HSK-A 100	1 - 7	4008E   ER 11	160	16	M8 x 1,25	281,00
A100.02.07.10.1	HSK-A 100	1 - 10	426E   ER 16	100	22	7/16" 20 UNF	218,00
A100.02.07.10.2	HSK-A 100	1 - 10	426E   ER 16	160	22	7/16" 20 UNF	281,00
A100.02.07.16.1	HSK-A 100	2 - 16	430E   ER 25	100	35	11/16" 16 UN	218,00
A100.02.07.16.2	HSK-A 100	2 - 16	430E   ER 25	160	35	11/16" 16 UN	281,00

**Lieferumfang:** Mit gewichteter Spannmutter  
**Delivery:** With balanced clamping nut  
**Livraison:** Avec écrou de serrage équilibré

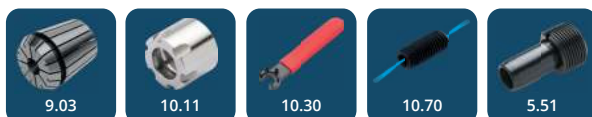

**Precision collet chuck ER for collets ISO 15488 (DIN 6499) ER-system**  
**Mandrin à pinces ER de précision pour pinces ISO 15488 (DIN 6499) système ER**



**Verwendung:**  
Zur Aufnahme von Werkzeugen mit  
Zylinderschaft in 3 µm-Spannzangen.

**Application:**  
For mounting straight-shank tools in  
3 µm-collets.

**Application:**  
Pour le serrage d'outils avec queue  
cylindrique dans des pinces de serrage  
3 µm.

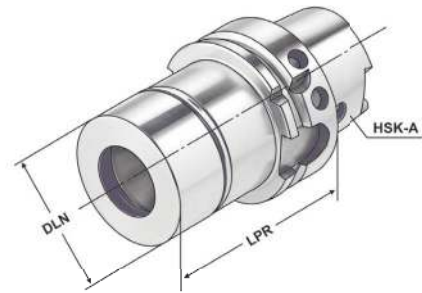

ISO 12164 | Form A | ≤ 3µm | G2.5 25.000 min<sup>-1</sup> | RFID Chip | ISO 15488

i 13.04

Bestell-Nr. Order no. Référence	HSK	DCONWS Spannbereich Capacity   Capacité	Typ	LPR	LB	DLN	THID	EUR
A40.P2.20.070	HSK-A 40	2 - 20	470E   ER 32	70	49,5	50	M16 x 2,0	125,00
A50.P2.20.080	HSK-A 50	2 - 20	470E   ER 32	70	53	50	M16 x 2,0	138,00
A63.P2.20.080	HSK-A 63	2 - 20	470E   ER 32	80	53	50	M16 x 2,0	99,00
A63.P2.20.100	HSK-A 63	2 - 20	470E   ER 32	100	73	50	M16 x 2,0	109,00
A63.P2.20.125	HSK-A 63	2 - 20	470E   ER 32	125	86	50	M16 x 2,0	119,00
A63.P2.20.150	HSK-A 63	2 - 20	470E   ER 32	150	111	50	M16 x 2,0	131,00
A63.P2.20.200	HSK-A 63	2 - 20	470E   ER 32	200	161	50	M16 x 2,0	146,00
A100.P2.20.100	HSK-A 100	2 - 20	470E   ER 32	100	61	50	M16 x 2,0	256,00
A100.P2.20.125	HSK-A 100	2 - 20	470E   ER 32	125	86	50	M16 x 2,0	272,00
A100.P2.20.150	HSK-A 100	2 - 20	470E   ER 32	150	111	50	M16 x 2,0	288,00
A100.P2.20.200	HSK-A 100	2 - 20	470E   ER 32	200	161	50	M16 x 2,0	320,00

5

**Vorteile:**

- Exzellente Rundlaufgenauigkeit im System (Futter + Spannzange + Spannmutter)
- Extreme Haltekraften (erhöht die Haltekraft um mindestens 60 % im Vergleich zu Standard ER-Futter)
- Glatte Spannmutter ohne Nuten für Hochgeschwindigkeitsbearbeitung

**Advantages:**

- Excellent concentricity in the system (chuck + collet + clamping nut)
- Extremely strong holding force (increases the holding power by at least 60% compared to standard ER chuck)
- Plain clamping nut without grooves for high speed machining

**Avantages:**

- Excellente concentricité du système (mandrin + pince de serrage + écrou de serrage)
- La force de rétention est extrêmement forte (augmente la force de rétention d'au moins 60 % par rapport aux mandrins ER standard)
- Ecrou de serrage lisse sans rainures pour l'usinage à grande vitesse

**Hinweis:**

Nur das Nennmaß DCONWS kann gespannt werden.

**Note:**

Only nominal size DCONWS can be clamped.

**Observation:**

Seulement la dimension nominale DCONWS peut être serrée.

**Lieferumfang:**

Inklusive Präzisions-Spannmutter

**Delivery:**

With precision clamping nut

**Livraison:**

Avec écrou de serrage de précision





Verwendung:

Zur Aufnahme von Werkzeugen mit Zylinderschaft nach DIN 1835 Form A+B+E und DIN 6535 Form HB+HE

Application:

For mounting straight-shank tools acc. DIN 1835 form A+B+E and DIN 6535 form HB+HE

Application:

Destiné à recevoir les outils avec les queues de forme cylindrique suivant DIN 1835 en forme A+B+E et DIN 6535 en forme HB+HE

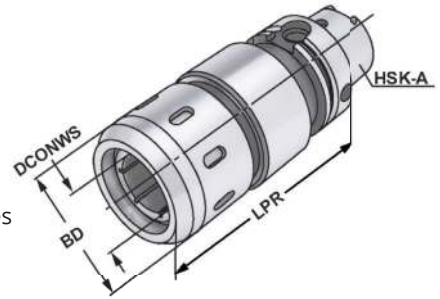

ISO 12164	Form A	≤ 3µm	G6.3 15.000 min <sup>-1</sup>	RFID Chip	HKS
-----------	--------	-------	-------------------------------	-----------	-----

13.04

5

Bestell-Nr. Order no. Référence	HSK	DCONWS Spannbereich Capacity   Capacité	Typ	DCONWS	LPR	BD	EUR
A63.64.20	HSK-A 63	3 - 20	HKS 20	20	95	53	338,00
A63.64.25	HSK-A 63	3 - 25	HKS 25	25	100	63	343,00
A63.64.32	HSK-A 63	3 - 32	HKS 32	32	110	68	348,00
A100.64.20	HSK-A 100	3 - 20	HKS 20	20	105	53	417,00
A100.64.25	HSK-A 100	3 - 25	HKS 25	25	105	63	431,00
A100.64.32	HSK-A 100	3 - 32	HKS 32	32	105	68	440,00

Größe Size Taille	20mm	25mm	32mm
Anzugsmoment Clamping torque Couple	50-70 Nm	80-100 Nm	80-100 Nm
Spannkraft Clamping force Tension	780 Nm	2000 Nm	2000 Nm

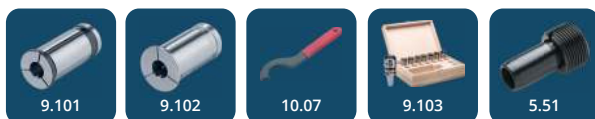

DISCOUNT  
**P&G 20%**



# RELEASE THE BEAST



KEMMLER

**K KEMMLER®**  
Präzisionswerkzeuge

**Verwendung:**

Zum Spannen von zylindrischen Werkzeugschäften mit seitlicher Spannfläche nach DIN 1835 Form B (Weldon).

**Application:**

For mounting straight-shank tools with lateral flat according to DIN 1835 form B (Weldon).

**Application:**

Pour le serrage d'outils avec queue cylindrique et avec méplat de serrage latérale suivant DIN 1835 forme B (Weldon).

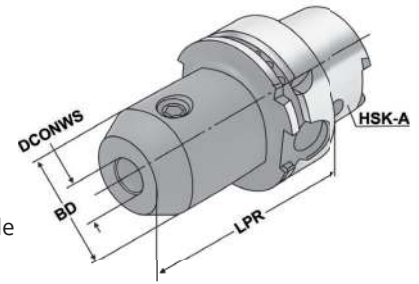

5

Bestell-Nr. Order no. Référence	HSK	DCONWS	TDCON	LPR	BD	EUR
A32.04.06	HSK-A 32	6	H4	60	25	109,00
A32.04.08	HSK-A 32	8	H4	60	28	109,00
A32.04.10	HSK-A 32	10	H4	65	35	109,00
A32.04.12	HSK-A 32	12	H4	70	42	109,00
A32.04.14	HSK-A 32	14	H4	75	44	109,00
A32.04.16	HSK-A 32	16	H4	75	48	109,00
A32.04.20	HSK-A 32	20	H4	90	50	109,00
A40.04.06	HSK-A 40	6	H4	60	25	112,00
A40.04.08	HSK-A 40	8	H4	60	28	112,00
A40.04.10	HSK-A 40	10	H4	60	35	112,00
A40.04.12	HSK-A 40	12	H4	70	42	112,00
A40.04.14	HSK-A 40	14	H4	75	44	112,00
A40.04.16	HSK-A 40	16	H4	75	40	112,00
A40.04.18	HSK-A 40	18	H4	85	40	112,00
A40.04.20	HSK-A 40	20	H4	85	40	112,00
A40.04.25	HSK-A 40	25	H4	100	45	122,00
A40.04.32	HSK-A 40	32	H4	105	60	125,00
A50.04.06	HSK-A 50	6	H4	65	25	115,00
A50.04.08	HSK-A 50	8	H4	65	28	115,00
A50.04.10	HSK-A 50	10	H4	65	35	115,00
A50.04.12	HSK-A 50	12	H4	80	42	115,00
A50.04.14	HSK-A 50	14	H4	80	44	115,00
A50.04.16	HSK-A 50	16	H4	80	48	115,00
A50.04.18	HSK-A 50	18	H4	80	50	115,00
A50.04.20	HSK-A 50	20	H4	80	52	115,00
A50.04.25	HSK-A 50	25	H4	110	60	125,00
A50.04.32	HSK-A 50	32	H4	110	60	130,00

**Hinweis:** Ab DCONWS = 25 mit zwei Spannschrauben  
**Note:** From DCONWS = 25 on two clamping screws  
**Observation:** A partir de DCONWS = 25 avec deux vis de serrage

**Lieferumfang:** Mit Spannschraube  
**Delivery:** With clamping screw  
**Livraison:** Avec vis de serrage



**Verwendung:**

Zum Spannen von zylindrischen Werkzeugschäften mit seitlicher Spannfläche nach DIN 1835 Form B (Weldon).

**Application:**

For mounting straight-shank tools with lateral flat according to DIN 1835 form B (Weldon).

**Application:**

Pour le serrage d'outils avec queue cylindrique et avec méplat de serrage latérale suivant DIN 1835 forme B (Weldon).

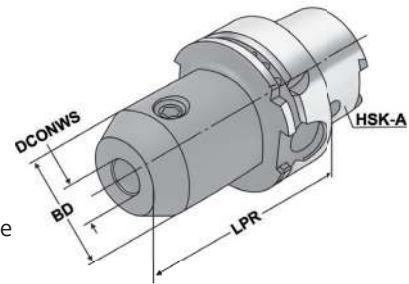

Bestell-Nr. Order no. Référence	HSK	DCONWS	TDCON	LPR	BD	EUR
A63.04.06	HSK-A 63	6	H4	65	25	110,00
A63.04.08	HSK-A 63	8	H4	65	28	102,00
A63.04.10	HSK-A 63	10	H4	65	35	102,00
A63.04.12	HSK-A 63	12	H4	80	42	102,00
A63.04.14	HSK-A 63	14	H4	80	44	102,00
A63.04.16	HSK-A 63	16	H4	80	48	102,00
A63.04.18	HSK-A 63	18	H4	80	50	102,00
A63.04.20	HSK-A 63	20	H4	80	52	102,00
A63.04.25	HSK-A 63	25	H4	110	65	118,00
A63.04.32	HSK-A 63	32	H4	110	72	125,00
A63.04.40	HSK-A 63	40	H4	125	80	154,00
A63.04.06.1	HSK-A 63	6	H4	100	25	128,00
A63.04.08.1	HSK-A 63	8	H4	100	28	123,00
A63.04.10.1	HSK-A 63	10	H4	100	35	123,00
A63.04.12.1	HSK-A 63	12	H4	100	42	123,00
A63.04.14.1	HSK-A 63	14	H4	100	44	123,00
A63.04.16.1	HSK-A 63	16	H4	100	48	123,00
A63.04.18.1	HSK-A 63	18	H4	100	50	123,00
A63.04.20.1	HSK-A 63	20	H4	100	52	123,00
A63.04.06.130	HSK-A 63	6	H4	130	25	133,00
A63.04.08.130	HSK-A 63	8	H4	130	28	133,00
A63.04.10.130	HSK-A 63	10	H4	130	35	133,00
A63.04.12.130	HSK-A 63	12	H4	130	42	133,00
A63.04.14.130	HSK-A 63	14	H4	130	44	133,00
A63.04.16.130	HSK-A 63	16	H4	130	48	133,00
A63.04.18.130	HSK-A 63	18	H4	130	50	133,00
A63.04.20.130	HSK-A 63	20	H4	130	52	133,00
A63.04.06.2	HSK-A 63	6	H4	160	25	144,00
A63.04.08.2	HSK-A 63	8	H4	160	28	144,00
A63.04.10.2	HSK-A 63	10	H4	160	35	144,00
A63.04.12.2	HSK-A 63	12	H4	160	42	144,00
A63.04.14.2	HSK-A 63	14	H4	160	44	144,00
A63.04.16.2	HSK-A 63	16	H4	160	48	144,00
A63.04.18.2	HSK-A 63	18	H4	160	50	144,00
A63.04.20.2	HSK-A 63	20	H4	160	52	144,00

**Verwendung:**

Zum Spannen von zylindrischen Werkzeugschäften mit seitlicher Spannfläche nach DIN 1835 Form B (Weldon).

**Application:**

For mounting straight-shank tools with lateral flat according to DIN 1835 form B (Weldon).

**Application:**

Pour le serrage d'outils avec queue cylindrique et avec méplat de serrage latérale suivant DIN 1835 forme B (Weldon).

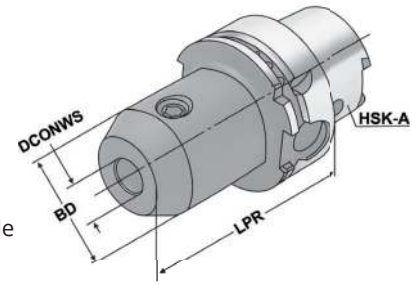
ISO  
12164Form  
ARFID  
ChipDIN  
1835-B

H4



13.04

5

Bestell-Nr. Order no. Référence	HSK	DCONWS	TDCON	LPR	BD	EUR
A100.04.06	HSK-A 100	6	H4	80	25	151,00
A100.04.08	HSK-A 100	8	H4	80	28	144,00
A100.04.10	HSK-A 100	10	H4	80	35	144,00
A100.04.12	HSK-A 100	12	H4	80	42	144,00
A100.04.14	HSK-A 100	14	H4	80	44	144,00
A100.04.16	HSK-A 100	16	H4	100	48	144,00
A100.04.18	HSK-A 100	18	H4	100	50	144,00
A100.04.20	HSK-A 100	20	H4	100	52	144,00
A100.04.25	HSK-A 100	25	H4	100	65	155,00
A100.04.32	HSK-A 100	32	H4	100	72	162,00
A100.04.40	HSK-A 100	40	H4	105	80	188,00
A100.04.06.2	HSK-A 100	6	H4	160	25	262,00
A100.04.08.2	HSK-A 100	8	H4	160	28	254,00
A100.04.10.2	HSK-A 100	10	H4	160	35	254,00
A100.04.12.2	HSK-A 100	12	H4	160	42	254,00
A100.04.14.2	HSK-A 100	14	H4	160	44	254,00
A100.04.16.2	HSK-A 100	16	H4	160	48	254,00
A100.04.18.2	HSK-A 100	18	H4	160	50	254,00
A100.04.20.2	HSK-A 100	20	H4	160	52	254,00
A100.04.25.2	HSK-A 100	25	H4	160	65	262,00
A100.04.32.2	HSK-A 100	32	H4	160	72	276,00
A100.04.40.2	HSK-A 100	40	H4	160	80	289,00

**Hinweis:** Ab DCONWS = 25 mit zwei Spannschrauben  
**Note:** From DCONWS = 25 on two clamping screws  
**Observation:** A partir de DCONWS = 25 avec deux vis de serrage

**Lieferumfang:** Mit Spannschraube  
**Delivery:** With clamping screw  
**Livraison:** Avec vis de serrage



**End mill holders DIN 6359 with coolant channels for end mills DIN 1835-B**  
**Porte-fraises DIN 6359 avec canaux d'arrosage pour queues cylindriques DIN 1835-B**



**Verwendung:**  
Zum Spannen von zylindrischen Werkzeugschäften mit seitlicher Spannfläche nach DIN 1835 Form B (Weldon). Mit Kühlkanälen für optimale Kühlung der Werkzeugschneide.

**Application:**  
For mounting straight-shank tools with lateral flat according to DIN 1835 form B (Weldon). With coolant channels for optimal coolant at the cutting edge.

**Application:**  
Pour le serrage d'outils avec queue cylindrique et avec méplat de serrage latéral suivant DIN 1835 forme B (Weldon). Avec canaux d'arrosage pour refroidissement optimal des coupes.

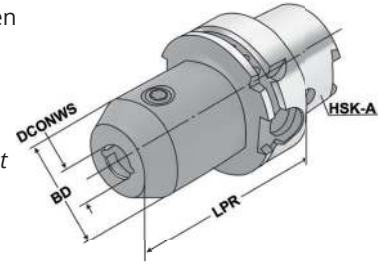

ISO 12164	Form A	$\leq 3\mu\text{m}$	G2.5 25.000 min <sup>-1</sup>	RFID Chip	DIN 1835-B	H4		13.04
-----------	--------	---------------------	-------------------------------	-----------	------------	----	--	-------

Bestell-Nr. Order no. Référence	HSK	DCONWS	TDCON	LPR	BD	EUR
A63.04.06.K	HSK-A 63	6	H4	65	25	123,00
A63.04.08.K	HSK-A 63	8	H4	65	28	116,00
A63.04.10.K	HSK-A 63	10	H4	65	35	116,00
A63.04.12.K	HSK-A 63	12	H4	80	42	116,00
A63.04.14.K	HSK-A 63	14	H4	80	44	116,00
A63.04.16.K	HSK-A 63	16	H4	80	48	116,00
A63.04.18.K	HSK-A 63	18	H4	80	50	116,00
A63.04.20.K	HSK-A 63	20	H4	80	52	116,00
A63.04.25.K	HSK-A 63	25	H4	110	65	137,00
A63.04.32.K	HSK-A 63	32	H4	110	72	144,00
A63.04.40.K	HSK-A 63	40	H4	125	80	157,00
A63.04.06.1.K	HSK-A 63	6	H4	100	25	132,00
A63.04.08.1.K	HSK-A 63	8	H4	100	28	132,00
A63.04.10.1.K	HSK-A 63	10	H4	100	35	132,00
A63.04.12.1.K	HSK-A 63	12	H4	100	42	132,00
A63.04.14.1.K	HSK-A 63	14	H4	100	44	132,00
A63.04.16.1.K	HSK-A 63	16	H4	100	48	132,00
A63.04.18.1.K	HSK-A 63	18	H4	100	50	132,00
A63.04.20.1.K	HSK-A 63	20	H4	100	52	132,00
A63.04.06.130.K	HSK-A 63	6	H4	130	25	158,00
A63.04.08.130.K	HSK-A 63	8	H4	130	28	152,00
A63.04.10.130.K	HSK-A 63	10	H4	130	35	152,00
A63.04.12.130.K	HSK-A 63	12	H4	130	42	152,00
A63.04.14.130.K	HSK-A 63	14	H4	130	44	152,00
A63.04.16.130.K	HSK-A 63	16	H4	130	48	152,00
A63.04.18.130.K	HSK-A 63	18	H4	130	50	152,00
A63.04.20.130.K	HSK-A 63	20	H4	130	52	152,00

**Hinweis:** Ab d = 25 mit zwei Spanschrauben  
d = 6 bis 18 mit zwei Kühlkanälen  
d = 20 bis 40 mit vier Kühlkanälen  
Für Werkzeuge mit innerer Kühlmittelzufuhr muss ein O-Ring eingesetzt werden.

**Note:** From d = 25 on two clamping screws  
d = 6 to 18 with two coolant channels  
d = 20 to 40 with four coolant channels  
For tools with through coolant an O-ring must be used.

**Observation:** À partir de d = 25 avec deux vis de serrage  
d = 6 bis 18 avec deux canaux d'arrosage  
d = 20 bis 40 avec quatre canaux d'arrosage  
Pour outils avec arrosage interne il faut utiliser un joint torique.



**Lieferumfang:**  
Delivery:  
Livraison:

Mit Spanschraube  
With clamping screw  
Avec vis de serrage







**End mill holders DIN 6359 with coolant channels for end mills DIN 1835-B**  
**Porte-fraises DIN 6359 avec canaux d'arrosage pour queues cylindriques DIN 1835-B**



**Verwendung:**  
Zum Spannen von zylindrischen Werkzeugschäften mit seitlicher Spannfläche nach DIN 1835 Form B (Weldon). Mit Kühlkanälen für optimale Kühlung der Werkzeugschneide.

**Application:**  
For mounting straight-shank tools with lateral flat according to DIN 1835 form B (Weldon). With coolant channels for optimal coolant at the cutting edge.

**Application:**  
Pour le serrage d'outils avec queue cylindrique et avec méplat de serrage latéral suivant DIN 1835 forme B (Weldon). Avec canaux d'arrosage pour refroidissement optimal des coupes.

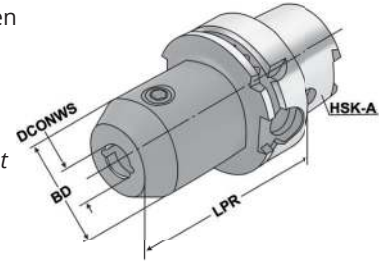

ISO 12164	Form A	≤ 3µm	G2,5 25.000 min <sup>-1</sup>	RFID Chip	DIN 1835-B	H4			13.04
-----------	--------	-------	-------------------------------	-----------	------------	----	--	--	-------

5

Bestell-Nr. Order no. Référence	HSK	DCONWS	TDCON	LPR	BD	EUR
A100.04.06.K	HSK-A 100	6	H4	80	25	163,00
A100.04.08.K	HSK-A 100	8	H4	80	28	157,00
A100.04.10.K	HSK-A 100	10	H4	80	35	157,00
A100.04.12.K	HSK-A 100	12	H4	80	42	157,00
A100.04.14.K	HSK-A 100	14	H4	80	44	157,00
A100.04.16.K	HSK-A 100	16	H4	100	48	157,00
A100.04.18.K	HSK-A 100	18	H4	100	50	157,00
A100.04.20.K	HSK-A 100	20	H4	100	52	157,00
A100.04.25.K	HSK-A 100	25	H4	100	65	181,00
A100.04.32.K	HSK-A 100	32	H4	100	72	192,00
A100.04.40.K	HSK-A 100	40	H4	105	80	203,00
A100.04.06.2.K	HSK-A 100	6	H4	160	25	388,00
A100.04.08.2.K	HSK-A 100	8	H4	160	28	371,00
A100.04.10.2.K	HSK-A 100	10	H4	160	35	371,00
A100.04.12.2.K	HSK-A 100	12	H4	160	42	371,00
A100.04.14.2.K	HSK-A 100	14	H4	160	44	371,00
A100.04.16.2.K	HSK-A 100	16	H4	160	48	371,00
A100.04.18.2.K	HSK-A 100	18	H4	160	50	371,00
A100.04.20.2.K	HSK-A 100	20	H4	160	52	371,00
A100.04.25.2.K	HSK-A 100	25	H4	160	65	387,00
A100.04.32.2.K	HSK-A 100	32	H4	160	72	401,00
A100.04.40.2.K	HSK-A 100	40	H4	160	80	417,00

**Hinweis:** Ab d = 25 mit zwei Spannschrauben  
d = 6 bis 18 mit zwei Kühlkanälen  
d = 20 bis 40 mit vier Kühlkanälen  
Für Werkzeuge mit innerer Kühlmittelzufuhr muss ein O-Ring eingesetzt werden.

**Note:** From d = 25 on two clamping screws  
d = 6 to 18 with two coolant channels  
d = 20 to 40 with four coolant channels  
For tools with through coolant an O-ring must be used.

**Observation:** À partir de d = 25 avec deux vis de serrage  
d = 6 bis 18 avec deux canaux d'arrosage  
d = 20 bis 40 avec quatre canaux d'arrosage  
Pour outils avec arrosage interne il faut utiliser un joint torique.

**Lieferumfang:** Mit Spannschraube  
**Delivery:** With clamping screw  
**Livraison:** Avec vis de serrage

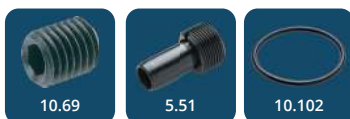

End mill holders DIN 6359 for end mills DIN 1835-E  
Porte-fraises DIN 6359 pour queues cylindriques DIN 1835-E

(DIN 69893-1 | HSK-A)



**Verwendung:**  
Zum Spannen von zylindrischen Werkzeugschäften mit geneigter Spannfläche nach DIN 1835 Form E (Whistle Notch).

**Application:**  
For mounting straight-shank tools and inclined flat according to DIN 1835 form E (Whistle Notch).

**Application:**  
Pour le serrage d'outils avec queue cylindrique et avec méplat incliné suivant DIN 1835 forme E (Whistle Notch).

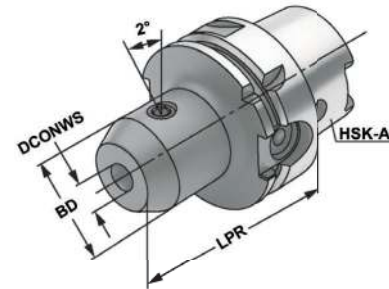

Bestell-Nr. Order no. Référence	HSK	DCONWS	TDCON	LPR	BD	EUR
A63.05.06	HSK-A 63	6	H4	80	25	113,00
A63.05.08	HSK-A 63	8	H4	80	28	107,00
A63.05.10	HSK-A 63	10	H4	80	35	107,00
A63.05.12	HSK-A 63	12	H4	90	42	107,00
A63.05.14	HSK-A 63	14	H4	90	44	107,00
A63.05.16	HSK-A 63	16	H4	100	48	107,00
A63.05.18	HSK-A 63	18	H4	100	50	107,00
A63.05.20	HSK-A 63	20	H4	100	52	107,00
A63.05.25	HSK-A 63	25	H4	110	65	124,00
A63.05.32	HSK-A 63	32	H4	110	72	132,00
A100.05.06	HSK-A 100	6	H4	90	25	153,00
A100.05.08	HSK-A 100	8	H4	90	28	147,00
A100.05.10	HSK-A 100	10	H4	90	35	147,00
A100.05.12	HSK-A 100	12	H4	100	42	147,00
A100.05.14	HSK-A 100	14	H4	100	44	147,00
A100.05.16	HSK-A 100	16	H4	100	48	147,00
A100.05.18	HSK-A 100	18	H4	100	50	147,00
A100.05.20	HSK-A 100	20	H4	110	52	147,00
A100.05.25	HSK-A 100	25	H4	120	65	172,00
A100.05.32	HSK-A 100	32	H4	120	72	181,00
A100.05.40	HSK-A 100	40	H4	120	80	194,00

5

**Hinweis:** Ab DCONWS = 25 mit zwei Spannschrauben  
**Note:** From DCONWS = 25 on two clamping screws  
**Observation:** A partir de DCONWS = 25 avec deux vis de serrage

**Lieferumfang:** Mit Spannschraube und axialer Verstellechraube  
**Delivery:** With clamping screw and axial adjustment bolt  
**Livraison:** Avec vis de serrage et vis de butée axiale



**Verwendung:**

Zur Aufnahme von Einschraubfräser mit Gewinde.

**Application:**

For mounting screw-in cutters with thread.

**Application:**

Pour le serrage de fraises à queue fileté.

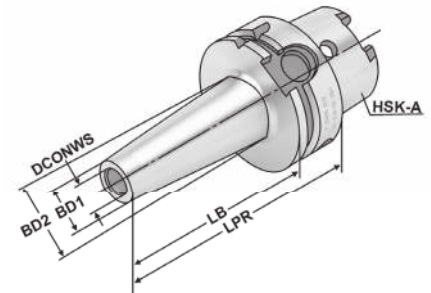

5

Bestell-Nr. Order no. Référence	HSK	THSZWS	DCONWS	BD1	BD2	LPR	LB	EUR
A63.06.06	HSK-A 63	M6	6,5	10	13	51	25	168,00
A63.06.08	HSK-A 63	M8	8,5	13	15	51	25	168,00
A63.06.08.1	HSK-A 63	M8	8,5	13	23	76	50	183,00
A63.06.08.2	HSK-A 63	M8	8,5	13	23	101	75	199,00
A63.06.10	HSK-A 63	M10	10,5	18	20	51	25	168,00
A63.06.10.1	HSK-A 63	M10	10,5	18	23	76	50	188,00
A63.06.10.3	HSK-A 63	M10	10,5	18	32	126	100	228,00
A63.06.10.5	HSK-A 63	M10	10,5	18	37	176	150	272,00
A63.06.12	HSK-A 63	M12	12,5	21	24	51	25	168,00
A63.06.12.1	HSK-A 63	M12	12,5	21	24	76	50	188,00
A63.06.12.2	HSK-A 63	M12	12,5	21	31	101	75	207,00
A63.06.12.3	HSK-A 63	M12	12,5	21	33	126	100	228,00
A63.06.12.5	HSK-A 63	M12	12,5	21	40	176	150	272,00
A63.06.16	HSK-A 63	M16	17	29	29	51	25	168,00
A63.06.16.1	HSK-A 63	M16	17	29	34	76	50	188,00
A63.06.16.2	HSK-A 63	M16	17	29	34	101	75	207,00
A63.06.16.3	HSK-A 63	M16	17	29	36	126	100	228,00
A63.06.16.5	HSK-A 63	M16	17	29	43	176	150	272,00
A100.06.08.1	HSK-A 100	M8	8,5	13	23	79	50	236,00
A100.06.10.1	HSK-A 100	M10	10,5	18	23	79	50	236,00
A100.06.10.3	HSK-A 100	M10	10,5	18	32	129	100	287,00
A100.06.10.5	HSK-A 100	M10	10,5	18	37	179	150	340,00
A100.06.12.1	HSK-A 100	M12	12,5	21	24	79	50	236,00
A100.06.12.3	HSK-A 100	M12	12,5	21	33	129	100	287,00
A100.06.12.5	HSK-A 100	M12	12,5	21	40	179	150	340,00
A100.06.16.1	HSK-A 100	M16	17	29	34	79	50	236,00
A100.06.16.3	HSK-A 100	M16	17	29	36	129	100	287,00
A100.06.16.5	HSK-A 100	M16	17	29	43	179	150	340,00

Empfohlenes Anzugsmoment  
Recommended tightening torques  
Torques de serrage recommandés

M6	10 Nm
M8	25 Nm
M10	40 Nm
M12	60 Nm
M16	50 Nm



Milling arbors for screw-in cutters - slim version

Porte-fraises pour fraises à queue fileté - type élané

**Verwendung:**

Zur Aufnahme von Einschraubfräser mit Gewinde.

**Application:**

For mounting screw-in cutters with thread.

**Application:**

Pour le serrage de fraises à queue fileté.

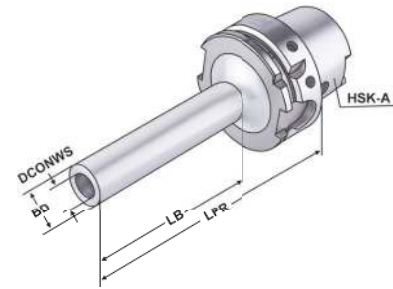
ISO  
12164Form  
ARFID  
Chip

H7

Bestell-Nr. Order no. Référence	HSK	THSZWS	DCONWS	BD	LPR	LB	EUR
A63.06.10.126.S	HSK-A 63	M10	10,5	18	126	100	211,00
A63.06.10.176.S	HSK-A 63	M10	10,5	18	176	150	250,00
A63.06.12.101.S	HSK-A 63	M12	12,5	21	101	75	187,00
A63.06.12.126.S	HSK-A 63	M12	12,5	21	126	100	211,00
A63.06.12.176.S	HSK-A 63	M12	12,5	21	176	150	250,00
A63.06.16.101.S	HSK-A 63	M16	17	29	101	75	187,00
A63.06.16.126.S	HSK-A 63	M16	17	29	126	100	211,00
A63.06.16.176.S	HSK-A 63	M16	17	29	176	150	250,00

5

Empfohlenes Anzugsmoment  
Recommended tightening torques  
Torques de serrage recommandés

M6	10 Nm
M8	25 Nm
M10	40 Nm
M12	60 Nm
M16	50 Nm



5.51



**Verwendung:**

Zur Aufnahme von Walzen-, Walzenstirnfräsern oder Messerköpfen mit Längs- oder Quernut.

**Application:**

For mounting milling cutters with transverse or longitudinal groove.

**Application:**

Destiné à recevoir les porte-fraises, les fraises cylindriques ou les têtes de fraisage avec rainure longitudinale et transversale.

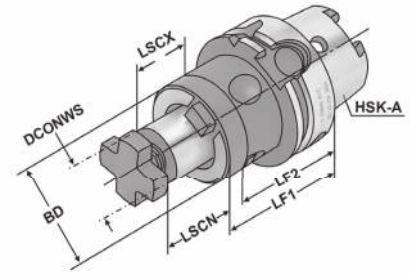

ISO 12164 | Form A | ≤ 5µm | G6,3 15.000 min<sup>-1</sup> | RFID Chip | DIN 6358 | h6

**5**

Bestell-Nr. Order no. Référence	HSK	DCONWS	TCDCON	LF1	LF2	LSCN	LSCX	BD	EUR
A32.10.16	HSK-A 32	16	h6	55	45	17	27	32	118,00
A32.10.22	HSK-A 32	22	h6	55	43	19	31	40	121,00
A32.10.27	HSK-A 32	27	h6	65	53	21	33	48	124,00
A40.10.16	HSK-A 40	16	h6	50	40	17	27	32	121,00
A40.10.22	HSK-A 40	22	h6	50	38	19	31	40	124,00
A40.10.27	HSK-A 40	27	h6	65	53	21	33	48	127,00
A50.10.16	HSK-A 50	16	h6	50	40	17	27	32	127,00
A50.10.22	HSK-A 50	22	h6	50	38	19	31	40	133,00
A50.10.27	HSK-A 50	27	h6	65	53	21	33	48	136,00
A50.10.32	HSK-A 50	32	h6	65	51	24	38	58	145,00
A63.10.16	HSK-A 63	16	h6	60	50	17	27	32	117,00
A63.10.22	HSK-A 63	22	h6	60	48	19	31	40	117,00
A63.10.27	HSK-A 63	27	h6	60	48	21	33	48	121,00
A63.10.32	HSK-A 63	32	h6	60	46	24	38	58	129,00
A63.10.40	HSK-A 63	40	h6	70	56	27	41	70	139,00
A63.10.16.1	HSK-A 63	16	h6	100	90	17	27	32	139,00
A63.10.22.1	HSK-A 63	22	h6	100	88	19	31	40	139,00
A63.10.27.1	HSK-A 63	27	h6	100	88	21	33	48	143,00
A63.10.32.1	HSK-A 63	32	h6	100	86	24	38	58	153,00

**Lieferumfang:** Mit Fräseranzugsschraube, Mitnehmerring und Passfeder  
**Delivery:** With tightening bolt, driving ring and feather key  
**Livraison:** Avec vis de serrage, bague d'entraînement et clavette





Combi shell mill holders DIN 6358  
Porte-fraises à double usage DIN 6358



**Verwendung:**  
Zur Aufnahme von Walzen-, Walzenstirnfräsern oder Messerköpfen mit Längs- oder Quernut.

**Application:**  
For mounting milling cutters with transverse or longitudinal groove.

**Application:**  
Destiné à recevoir les porte-fraises, les fraises cylindriques ou les têtes de fraiseage avec rainure longitudinale et transversale.

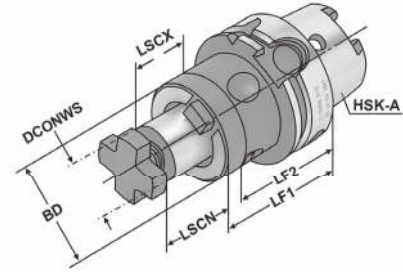

ISO 12164    Form A     $\leq 5\mu\text{m}$     G6.3 15.000 min<sup>-1</sup>    RFID Chip    DIN 6358    h6

Bestell-Nr. Order no. Référence	HSK	DCONWS	TCDCON	LF1	LF2	LSCN	LSCX	BD	EUR
A100.10.16	HSK-A 100	16	h6	60	50	17	27	32	149,00
A100.10.22	HSK-A 100	22	h6	60	48	19	31	40	149,00
A100.10.27	HSK-A 100	27	h6	60	48	21	33	48	152,00
A100.10.32	HSK-A 100	32	h6	60	46	24	38	58	161,00
A100.10.40	HSK-A 100	40	h6	70	56	27	41	70	175,00
A100.10.16.1	HSK-A 100	16	h6	100	90	17	27	32	361,00
A100.10.22.1	HSK-A 100	22	h6	100	88	19	31	40	361,00
A100.10.27.1	HSK-A 100	27	h6	100	88	21	33	48	370,00
A100.10.32.1	HSK-A 100	32	h6	100	86	24	38	58	395,00
A100.10.40.1	HSK-A 100	40	h6	100	86	27	41	70	428,00
A100.10.16.2	HSK-A 100	16	h6	160	150	17	27	32	578,00
A100.10.22.2	HSK-A 100	22	h6	160	148	19	31	40	578,00
A100.10.27.2	HSK-A 100	27	h6	160	148	21	33	48	592,00
A100.10.32.2	HSK-A 100	32	h6	160	146	24	38	58	631,00
A100.10.40.2	HSK-A 100	40	h6	160	146	27	41	70	685,00

5

**Lieferumfang:** Mit Fräseranzugsschraube, Mitnehmerring und Passfeder  
**Delivery:** With tightening bolt, driving ring and feather key  
**Livraison:** Avec vis de serrage, bague d'entraînement et clavette





Shell mill holders DIN 6357 with enlarged contact face and coolant exit bores on the end face  
Porte-fraises à trou lisse DIN 6357 avec surface de contact agrandie et arrosage frontal



**Verwendung:**  
Zur Aufnahme von Messerköpfen und Fräsern mit Quernut.

**Application:**  
For mounting milling cutters with transversal groove.

**Application:**  
Destiné à recevoir les fraises et les fraises avec des rainures transversales.

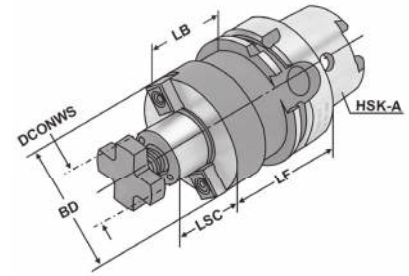

ISO 12164 Form A  $\leq 5\mu\text{m}$  G2,5 25.000 min<sup>-1</sup> RFID Chip DIN 6357 h6

5

Bestell-Nr. Order no. Référence	HSK	DCONWS	TCDCON	LF	LSC	LB	BD	EUR
A40.11.16	HSK-A 40	16	h6	50	17	30	40	115,00
A40.11.22	HSK-A 40	22	h6	50	19	30	48	116,00
A40.11.27	HSK-A 40	27	h6	55	21	35	60	117,00
A50.11.16	HSK-A 50	16	h6	50	17	24	40	116,00
A50.11.22	HSK-A 50	22	h6	60	19	34	48	117,00
A50.11.27	HSK-A 50	27	h6	60	21	34	60	118,00
A63.11.16	HSK-A 63	16	h6	50	17	24	38	124,00
A63.11.22	HSK-A 63	22	h6	50	19	24	48	124,00
A63.11.27	HSK-A 63	27	h6	60	21	34	58	124,00
A63.11.32	HSK-A 63	32	h6	60	24	34	78	129,00
A63.11.40	HSK-A 63	40	h6	60	27	34	88	162,00
A63.11.16.1	HSK-A 63	16	h6	100	17	74	38	151,00
A63.11.22.1	HSK-A 63	22	h6	100	19	74	48	151,00
A63.11.27.1	HSK-A 63	27	h6	100	21	74	58	151,00
A63.11.32.1	HSK-A 63	32	h6	100	24	74	78	155,00
A63.11.40.1	HSK-A 63	40	h6	100	27	74	88	192,00
A63.11.16.130	HSK-A 63	16	h6	130	17	104	38	220,00
A63.11.22.130	HSK-A 63	22	h6	130	19	104	48	220,00
A63.11.27.130	HSK-A 63	27	h6	130	21	104	58	220,00
A63.11.32.130	HSK-A 63	32	h6	130	24	104	78	229,00
A63.11.40.130	HSK-A 63	40	h6	130	27	104	88	282,00
A63.11.16.2	HSK-A 63	16	h6	160	17	134	38	225,00
A63.11.22.2	HSK-A 63	22	h6	160	19	134	48	225,00
A63.11.27.2	HSK-A 63	27	h6	160	21	134	58	225,00
A63.11.32.2	HSK-A 63	32	h6	160	24	134	78	239,00
A63.11.40.2	HSK-A 63	40	h6	160	27	134	88	283,00

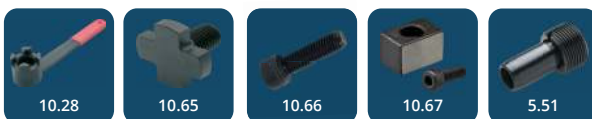



Shell mill holders DIN 6357 with enlarged contact face and coolant exit bores on the end face  
 Porte-fraises à trou lisse DIN 6357 avec surface de contact agrandie et arrosage frontal



**Verwendung:**  
 Zur Aufnahme von Messerköpfen und Fräsern mit Quernut.  
**Application:**  
 For mounting milling cutters with transversal groove.  
**Application:**  
 Destiné à recevoir les fraises et les fraises avec des rainures transversales.

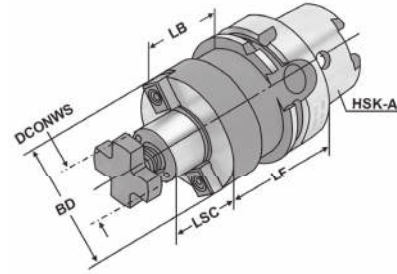

Bestell-Nr. Order no. Référence	HSK	DCONWS	TCDCON	LF	LSC	LB	BD	EUR
A100.11.16	HSK-A 100	16	h6	50	17	21	38	157,00
A100.11.22	HSK-A 100	22	h6	50	19	21	48	157,00
A100.11.27	HSK-A 100	27	h6	50	21	21	58	157,00
A100.11.32	HSK-A 100	32	h6	50	24	21	78	161,00
A100.11.40	HSK-A 100	40	h6	70	27	41	88	183,00
A100.11.60	HSK-A 100	60	h6	70	40	41	130	218,00
A100.11.16.1	HSK-A 100	16	h6	100	17	71	38	180,00
A100.11.22.1	HSK-A 100	22	h6	100	19	71	48	180,00
A100.11.27.1	HSK-A 100	27	h6	100	21	71	58	180,00
A100.11.32.1	HSK-A 100	32	h6	100	24	71	78	185,00
A100.11.40.1	HSK-A 100	40	h6	100	27	71	88	192,00
A100.11.16.2	HSK-A 100	16	h6	160	17	131	38	227,00
A100.11.22.2	HSK-A 100	22	h6	160	19	131	48	227,00
A100.11.27.2	HSK-A 100	27	h6	160	21	131	58	230,00
A100.11.32.2	HSK-A 100	32	h6	160	24	131	78	237,00
A100.11.40.2	HSK-A 100	40	h6	160	27	131	88	249,00
A100.11.16.3	HSK-A 100	16	h6	200	17	171	38	357,00
A100.11.22.3	HSK-A 100	22	h6	200	19	171	48	357,00
A100.11.27.3	HSK-A 100	27	h6	200	21	171	58	362,00
A100.11.32.3	HSK-A 100	32	h6	200	24	171	78	372,00
A100.11.40.3	HSK-A 100	40	h6	200	27	171	88	391,00

5

**DCONWS = 40 & 60** Für große Planfräser mit vier zusätzlichen Gewindebohrungen nach DIN 2079.  
 For large diameter face mill cutters with four additional threaded holes according to DIN 2079.  
 Pour fraises à surfacer à grands diamètres avec 4 taraudages supplémentaires suivant DIN 2079.

**Lieferumfang:** Mit Mitnehmersteinen, Kreuzschraube und Zylinderkopfschraube nach DIN 912 für Fräser mit innerer Kühlmittelzufuhr.  
 Bei DCONWS = 60 nur mit vier Befestigungsschrauben nach DIN 912.

**Delivery:** With drivers, cross head retaining screw and cylinder head retaining screw for cutters with central coolant.  
 For DCONWS = 60 only with four fixation screws according to DIN 912.

**Livraison:** Avec tenon d'entraînement, vis cruciforme et vis à têtes cylindrique suivant DIN 912 pour les fraises avec arrosage central.  
 Pour DCONWS = 60 est seulement avec quatre vis de fixation suivant DIN 912.

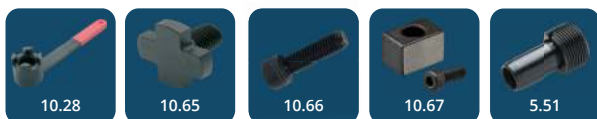





**Verwendung:**  
Zur Aufnahme von Werkzeugen mit Morsekegelschaft und Austreibblappen nach DIN 228-1 Form B.

**Application:**  
For mounting tools with Morse taper shank and tang according to DIN 228-1 form B.

**Application:**  
Pour le serrage d'outils avec queue cône Morse et tenon suivant DIN 228-1 forme B.

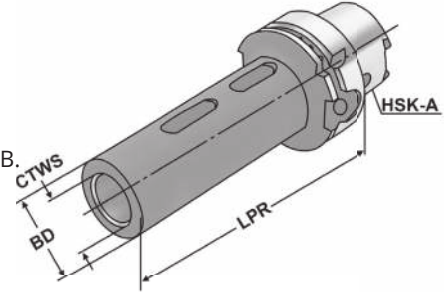

ISO 12164	Form A	≤ 5µm	G6.3 15.000 min <sup>-1</sup>	RFID Chip	DIN 6383	AT5
-----------	--------	-------	-------------------------------	-----------	----------	-----

5

Bestell-Nr. Order no. Référence	HSK	CTWS	TDCON	LPR	BD	EUR
A63.07.01	HSK-A 63	1	AT5	100	25	94,00
A63.07.02	HSK-A 63	2	AT5	120	32	96,00
A63.07.03	HSK-A 63	3	AT5	140	40	97,00
A63.07.04	HSK-A 63	4	AT5	160	48	100,00
A100.07.01	HSK-A 100	1	AT5	110	25	132,00
A100.07.02	HSK-A 100	2	AT5	120	32	135,00
A100.07.03	HSK-A 100	3	AT5	150	40	137,00
A100.07.04	HSK-A 100	4	AT5	170	48	144,00
A100.07.05	HSK-A 100	5	AT5	200	63	153,00





**Verwendung:**  
Zum Spannen von Werkzeugen mit Morsekegelschaft und Anzugsgewinde nach DIN 228-1 Form A.

**Application:**  
For clamping tools with Morse taper shank and thread according to DIN 228-1 form A.

**Application:**  
Pour le serrage d'outils avec queue cône Morse et filetage suivant DIN 228-1 forme A.

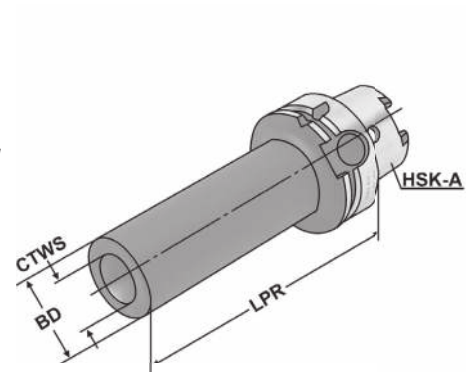

ISO 12164    Form A     $\leq 5\mu\text{m}$     G6.3 15.000 min<sup>-1</sup>    RFID Chip    DIN 6364    AT5

Bestell-Nr. Order no. Référence	HSK	CTWS	THID	LPR	BD	EUR
A63.08.01	HSK-A 63	1	M6	100	25	115,00
A63.08.02	HSK-A 63	2	M10	120	32	115,00
A63.08.03	HSK-A 63	3	M12	140	40	121,00
A63.08.04	HSK-A 63	4	M16	160	48	132,00
A100.08.01	HSK-A 100	1	M6	110	25	160,00
A100.08.02	HSK-A 100	2	M10	120	32	160,00
A100.08.03	HSK-A 100	3	M12	150	40	165,00
A100.08.04	HSK-A 100	4	M16	170	48	171,00
A100.08.05	HSK-A 100	5	M20	200	63	180,00

5

**Lieferumfang:** Mit eingebauter Fräseranzugsschraube  
**Delivery:** With built-in tightening bolt  
**Livraison:** Avec vis de serrage montée

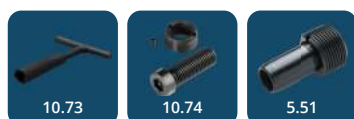



**Quick change tapping chucks with length compensation on compression and expansion**  
Mandrins de taraudage à changement rapide avec compensation longitudinale à la compression et traction



**Verwendung:**  
Zur Aufnahme von Schnellwechsel-Ein-  
sätzen für Gewindebohrer.  
**Application:**  
For the chucking of quick change adaptors  
for taps.  
**Application:**  
Pour le serrage d'adaptateurs porte-  
tarauds à changement rapide.

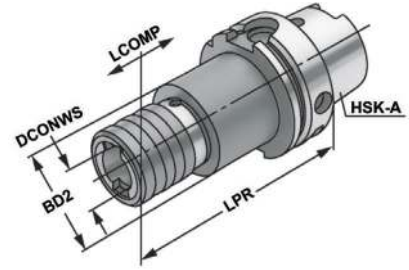

ISO 12164    Form A       RFID Chip

13.04

**5**

Bestell-Nr. Order no. Référence	HSK	Spannbereich Capacity Capacité	SZID	DCONWS	LPR	BD2	LCOMP	EUR
A40.16.12	HSK-A 40	M3 - M14	1	19	95	36	7	360,00
A50.16.12	HSK-A 50	M3 - M14	1	19	100	36	7	370,00
A50.16.20	HSK-A 50	M5 - M22	2	31	140	53	12	390,00
A63.16.12	HSK-A 63	M3 - M14	1	19	102	50	7	361,00
A63.16.20	HSK-A 63	M5 - M22	2	31	140	54	12	394,00
A63.16.36	HSK-A 63	M14 - M36	3	48	210	86	17,5	475,00
A100.16.12	HSK-A 100	M3 - M14	1	19	112	38	7	493,00
A100.16.20	HSK-A 100	M5 - M22	2	31	148	54	12	542,00
A100.16.36	HSK-A 100	M14 - M36	3	48	210	86	17,5	640,00

**Hinweis:** Für Bearbeitungszentren ohne Synchronspindel.  
**Note:** For machining centres without synchronous spindle.  
**Observation:** Pour centres d'usinage sans broche synchrone.



**Quick change tapping chucks without length compensation on compression and expansion**  
Mandrins de taraudage à changement rapide sans compensation longitudinale à la compression et traction



**Verwendung:**  
Zur Aufnahme von Schnellwechsel-Ein-  
sätzen für Gewindebohrer.  
**Application:**  
*For the chucking of quick change adaptors  
for taps.*  
**Application:**  
Pour le serrage d'adaptateurs porte-  
tarauds à changement rapide.

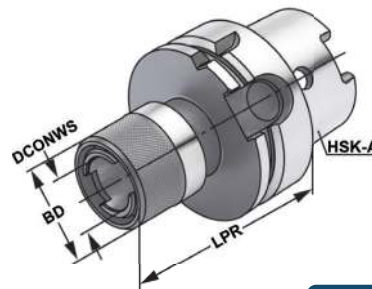

Bestell-Nr. Order no. Référence	HSK	Spannbereich Capacity Capacité	SZID	DCONWS	LPR	BD	EUR
A63.16.12.1	HSK-A 63	M3 - M14	1	19	65	38	216,00
A63.16.20.1	HSK-A 63	M5 - M22	2	31	100	54	227,00
A100.16.12.1	HSK-A 100	M3 - M14	1	19	80	38	327,00
A100.16.20.1	HSK-A 100	M5 - M22	2	31	90	54	402,00
A100.16.36.1	HSK-A 100	M14 - M36	3	48	130	86	497,00

5

**Hinweis:** Für Bearbeitungszentren mit Synchronspindel.  
**Note:** For machining centres with synchronous spindle.  
**Observation:** Pour centres d'usinage avec broche synchrone.





*Tapping chucks for synchronisation for collets ISO 15488 (DIN 6499) ER-system*  
Mandrins de taraudage pour synchronisation pour pinces ISO 15488 (DIN 6499) système ER



**Verwendung:**  
Für Bearbeitungszentren mit Synchronspindel.  
**Application:**  
*For machining centres with synchronous spindle.*  
**Application:**  
Pour centres d'usinage avec broche synchrone.

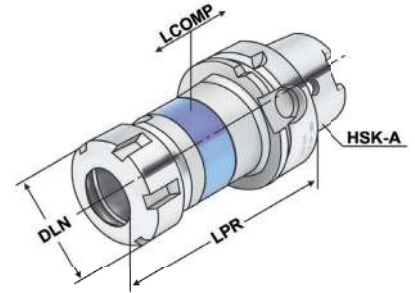

ISO 12164 | Form A |  $\leq 60\mu\text{m}$  | G6.3 15.000 min<sup>-1</sup> | RFID Chip | ISO 15488 |  $\pm$

i  
13.04

5

Bestell-Nr. Order no. Référence	HSK	DCONWS Spannbereich Capacity   Capacité	Typ	LPR	DLN	LCOMP	EUR
A63.16.02.10 <sup>1</sup>	HSK-A 63	M3 – M12	426E   ER 16   SW25	93	28	0,5	311,00
A63.16.02.10.M <sup>2</sup>	HSK-A 63	M3 – M12	426E   ER 16   Mini	93	22	0,5	319,00
A63.16.02.10.1.M <sup>2</sup>	HSK-A 63	M3 – M12	426E   ER 16   Mini	100	22	0,5	311,00
A63.16.02.13	HSK-A 63	M3 – M16	428E   ER 20	94	34	0,5	319,00
A63.16.02.16	HSK-A 63	M3 – M20	430E   ER 25	98	42	0,5	330,00
A63.16.02.20	HSK-A 63	M3 – M27	470E   ER 32	108	50	0,5	345,00
A63.16.02.26	HSK-A 63	M3 – M33	472E   ER 40	133,5	63	0,5	345,00
A100.16.02.10 <sup>1</sup>	HSK-A 100	M3 – M12	426E   ER 16   SW25	96	28	0,5	378,00
A100.16.02.10.1.M <sup>2</sup>	HSK-A 100	M3 – M12	426E   ER 16   Mini	106	22	0,5	378,00
A100.16.02.13	HSK-A 100	M3 – M16	428E   ER 20	97	34	0,5	389,00
A100.16.02.16	HSK-A 100	M3 – M20	430E   ER 25	101	42	0,5	389,00
A100.16.02.20	HSK-A 100	M3 – M27	470E   ER 32	110	50	0,5	389,00
A100.16.02.26	HSK-A 100	M3 – M33	472E   ER 40	133	63	0,5	410,00

<sup>1</sup> Sechskantmutter                      <sup>2</sup> Minimutter  
<sup>1</sup> Hexagonal clamping nut        <sup>2</sup> Mini nut  
<sup>1</sup> Écrous hexagonal                    <sup>2</sup> Écrous mini

**Lieferumfang:** Mit gewuchteter Spannmutter  
**Delivery:** With balanced clamping nut  
**Livraison:** Avec écrou de serrage équilibré

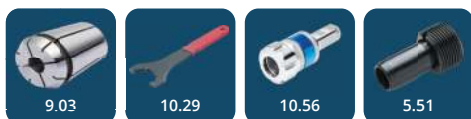

**Verwendung:**

Zur Aufnahme von allen nach DIN 6595 genormten Vollbohrern mit Zylinderschaft.

**Application:**

For all solid drills with cylindrical shank according to DIN 6595.

**Application:**

Pour le serrage de forets à queue cylindrique suivant DIN 6595.

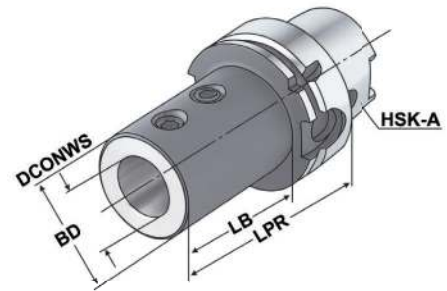

Bestell-Nr. Order no. Référence	HSK	DCONWS	LPR	BD	LB	EUR
A63.51.20	HSK-A 63	20	80	40	54	136,00
A63.51.25	HSK-A 63	25	90	45	64	136,00
A63.51.32	HSK-A 63	32	90	52	64	136,00
A63.51.40	HSK-A 63	40	105	63	79	145,00
A100.51.20	HSK-A 100	20	90	40	61	233,00
A100.51.25	HSK-A 100	25	95	45	66	233,00
A100.51.32	HSK-A 100	32	100	52	71	233,00
A100.51.40	HSK-A 100	40	110	60	81	248,00

5

**Lieferumfang:** Mit Spannschrauben  
**Delivery:** With clamping screws  
**Livraison:** Avec vis de serrage





**Verwendung:**  
Zur Aufnahme von Werkzeugen mit Zylinderschaft.

**Application:**  
For mounting tools with straight shanks.

**Application:**  
Pour le serrage d'outils avec queue cylindrique.

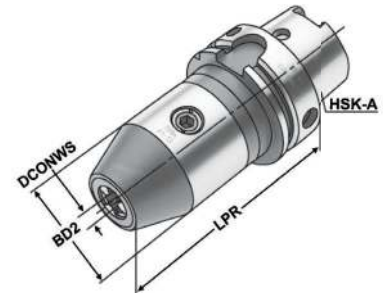
**5**

Bestell-Nr. Order no. Référence	HSK	DCONWS Spannbereich Capacity   Capacité	LPR	BD2	DRVS	EUR
A32.15.08	HSK-A 32	0,5 - 8	90	36	4	381,00
A40.15.08	HSK-A 40	0,5 - 8	90	36	4	381,00
A40.15.13	HSK-A 40	1,0 - 13	121	50	6	384,00
A40.15.16	HSK-A 40	2,5 - 16	126	50	6	390,00
A50.15.08	HSK-A 50	0,5 - 8	90	36	4	381,00
A50.15.13	HSK-A 50	1,0 - 13	116	50	6	384,00
A50.15.16	HSK-A 50	2,5 - 16	116	50	6	390,00
A63.15.08	HSK-A 63	0,5 - 8	85	36	4	290,00
A63.15.13	HSK-A 63	1,0 - 13	104	50	6	260,00
A63.15.16	HSK-A 63	2,5 - 16	109	50	6	270,00
A100.15.13	HSK-A 100	1,0 - 13	107	50	6	402,00
A100.15.16	HSK-A 100	2,5 - 16	112	50	6	446,00

**Hinweis:** Hohe Präzision und Rundlaufgenauigkeit von  $\leq 0,03$  mm. Kein selbständiges Lösen der Spannung während der Bearbeitung bei Links- oder Rechtslauf, sowie bei Spindelstop. Spannen und Lösen mit Sechskantschlüssel.

**Note:** High precision and accurate concentricity of  $\leq 0.03$  mm. No automatic slacking of the clamping force while machining with either clockwise or counter clockwise rotation or on spindle stop. Clamping and releasing effected by means of an Allen wrench.

**Remarque:** Précision élevée et exactitude de circularité de  $\leq 0,03$  mm. Pas de desserage autonome pendant l'usinage lors de la rotation à gauche ou à droite, ainsi que lors de l'arrêt de la broche. Serrage et desserage avec la clé hexagonale.

**Lieferumfang:** Ohne Spannschlüssel  
**Delivery:** Without wrench  
**Livraison:** Sans clé de serrage

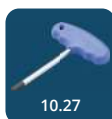

Boring bar blanks  
Barres d'alésage

**Verwendung:**  
Zur Herstellung von Sonderwerkzeugen.

**Application:**  
For the manufacturing of special tools.

**Application:**  
Pour la fabrication d'outils spéciaux.

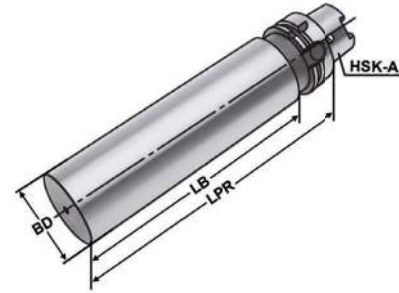
ISO  
12164Form  
ARFID  
Chip

Bestell-Nr. Order no. Référence	HSK	BD	LPR	LB	EUR
A32.17.25	HSK-A 32	32,5	100	65	120,00
A40.17.40	HSK-A 40	40,5	160	125	125,00
A50.17.50	HSK-A 50	50,5	200	158	140,00
A63.17.63	HSK-A 63	63,5	250	208	139,00
A63.17.80	HSK-A 63	80,0	250	208	176,00
A100.17.97	HSK-A 100	97,5	250	234	238,00

5

**Ausführung:** Kegel und Bund gehärtet und geschliffen. Schaft weich zur weiteren Bearbeitung.  
**Version:** Cone and flange hardened and grinded. Soft body for later processing.  
**Version:** Cône et collerette durcis et rectifiés. Corps doux pour un usinage ultérieur.



5.51





Reducing adapter for adaption from HSK to PSC (ISO 12164 to ISO 26623-1)  
Douille de réduction pour adaptation de HSK à PSC (ISO 12164 à ISO 26623-1)



**Verwendung:**  
Zur Adaption von HSK-A auf PSK  
(ISO 12164 auf ISO 26623-1)

**Application:**  
For adaption from HSK-A to PSK  
(ISO 12164 to ISO 26623-1)

**Application:**  
Pour adaptation de HSK-A à PSK  
(ISO 12164 à ISO 26623-1).

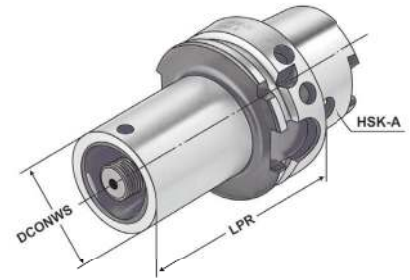
ISO  
12164Form  
ARFID  
ChipISO  
26623

5

Bestell-Nr. Order no. Référence	HSK	Typ	DCONWS	LPR	TQX	THID	EUR
A63.09.C3	HSK-A 63	PSK C3	32	75	45	M12x1,5	390,00
A63.09.C4	HSK-A 63	PSK C4	40	80	55	M14x1,5	390,00
A63.09.C5	HSK-A 63	PSK C5	50	90	95	M16x1,5	390,00
A100.09.C3.080	HSK-A 100	PSK C3	30	80	45	M14x1,5	430,00
A100.09.C4.090	HSK-A 100	PSK C4	40	90	55	M16x1,5	430,00
A100.09.C5.100	HSK-A 100	PSK C5	50	100	95	M16x1,5	440,00
A100.09.C6.110	HSK-A 100	PSK C6	63	110	170	M14x1,5	450,00

**Ausführung:**

Adapter HSK / PSK mit Axialspannung. Innen und außen geschliffen. Das im PSK-Werkzeughalter für Kühlmittel-Rohre vorgesehene Innengewinde wird mit der im Adapter integrierten Zylinderkopfschraube verschraubt. Spannschraube durchbohrt, somit ist das System für Innenkühlung geeignet.

Passend für Werkzeugaufnahmen mit Polygonschaft (PSC/PSK) ISO 26623-1.

**Version:**

Adapters HSK / PSK with axial clamping. Ground internally and externally. The internal thread provided for the coolant tube in the PSC toolholder is plugged with the socket-head screw incorporated in the adapter. The clamping screw incorporates a through hole, so the system is suitable for through-coolant feed.

Suitable for tool arbor with polygonal shank (PSC) - ISO 26623-1.

**Exécution:**

Adaptateurs HSK / PSK Tension axiale. Intérieur et extérieur rectifiés. Le filetage intérieur prévu pour les conduits d'arrosage dans le porte-outils PSC est vissé à l'aide de la vis à tête cylindrique intégrée dans l'adaptateur. Système adapté à l'arrosage interne grâce à la vis de serrage percée.

Pour la réception d'outils PSK ISO 26623-1.

**Lieferumfang:** Mit Spannschraube  
**Delivery:** Clamping screw  
**Livraison:** Avec vis de serrage



10.77



10.76



5.51



**Verwendung:**

Zur Aufnahme von Werkzeugen mit Zylinderschaft. Besonders im Werkzeug- und Formenbau wo reduzierte Störkontur gefordert ist.

**Application:**

For mounting straight-shank tools. Especially in operations in toolmaking and mould making. Wherever reduced interference contours are required.

**Application:**

Pour le serrage d'outils avec queue cylindrique. Particulièrement dans la fabrication d'outils et de moules. Applications nécessitant un encombrement réduit.

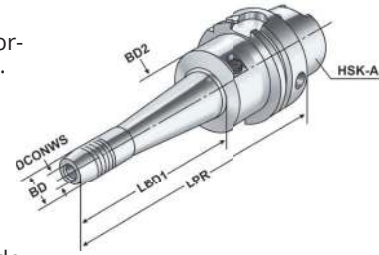

ISO 12164	Form A	$\leq 3\mu\text{m}$	G2.5 25.000 min <sup>-1</sup>	RFID Chip	i 13.04
-----------	--------	---------------------	-------------------------------	-----------	---------

Bestell-Nr. Order no. Référence	HSK	DCONWS	LPR	BD	BD2	LSCX	ADJRGA	LBD1	DRVS	THID	EUR
A63.HSL06.160	HSK-A 63	6	160	16	50	37	10	103	5	M6x1	539,00
A63.HSL08.160	HSK-A 63	8	160	18	50	37	10	103	5	M6x1	539,00
A63.HSL10.160	HSK-A 63	10	160	20	50	42	10	103	5	M8x1	539,00
A63.HSL12.160	HSK-A 63	12	160	22	50	47	10	104	5	M8x1	539,00

5

LSCX = Einspannlänge, max.      ADJRGA = Verstellweg, max.  
 LSCX = Clamping depth, max.    ADJRGA = Length adjustment range, max.  
 LSCX = Profondeur d'insertion, max.    ADJRGA = Course de réglage, max.

Lieferumfang: Ohne Spannschlüssel  
 Delivery: Without wrench  
 Livraison: Sans clé de serrage

**Gewuchtete Ausführung**

Balanced type  
 Type équilibré



Bestell-Nr. Order no. Référence	Ausführung Version Exécution
---------------------------------------	------------------------------------

**Wuchten auf G 2,5 von vorgewuchteten Kemmler-Werkzeugen**

Balancing at G 2.5 of pre-balanced Kemmler-tools  
 Équilibrage G 2,5 d'outils Kemmler pré-équilibrés

W25 **Ohne Wuchtprotokoll**  
 Without balancing report  
 Sans protocole d'équilibrage

W25.2 **Mit Wuchtprotokoll**  
 With balancing report  
 Avec protocole d'équilibrage

Wuchten von nicht vorgewuchteten Werkzeugen  
 Balancing of unbalanced tools  
 Équilibrage d'outils non-équilibrés

W25.1 **Ohne Wuchtprotokoll**  
 Without balancing report  
 Sans protocole d'équilibrage



**Verwendung:**

Zur Aufnahme von Werkzeugen mit Zylinderschaft nach DIN 1835 Form A+B+E und DIN 6535 Form HB+HE (größer Ø 20 mm nur mit Reduzierung).

**Application:**

For mounting straight-shank tools acc. DIN 1835 form A+B+E and DIN 6535 form HB+HE (larger than Ø 20 mm only with reduction sleeve).

**Application:**

Pour le serrage d'outils avec queue cylindrique suivant DIN 1835 forme A+B+E et DIN 6535 forme HB+HE (à partir de Ø 20 mm seulement avec réduction).

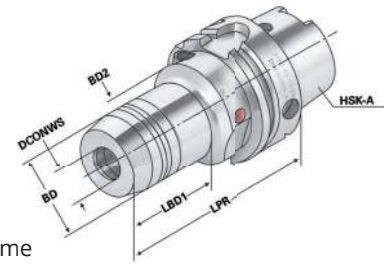

5

Bestell-Nr. Order no. Référence	HSK	DCONWS	LPR	BD	BD2	LSCX	ADJRGA	LBD1	DRVS	THID	EUR
A32.H06	HSK-A 32	6	80	26	33	37	10	31	5	M6x1	360,00
A32.H08	HSK-A 32	8	80	28	35	37	10	31	5	M6x1	360,00
A32.H10	HSK-A 32	10	85	30	37	42	10	36	5	M6x1	360,00
A32.H12	HSK-A 32	12	90	32	39	47	10	41	5	M6x1	360,00
A32.H14	HSK-A 32	14	95	34	26	47	10	60	5	M6x1	360,00
A32.H16	HSK-A 32	16	100	38	40	52	10	51	5	M8x1	360,00
A32.H20	HSK-A 32	20	100	42	42	52	10	65	5	M8x1	360,00
A40.H06	HSK-A 40	6	80	26	33,5	37	10	33	5	M6x1	360,00
A40.H08	HSK-A 40	8	80	28	33,5	37	10	33,5	5	M6x1	360,00
A40.H10	HSK-A 40	10	85	30	33,5	42	10	39	5	M6x1	360,00
A40.H12	HSK-A 40	12	90	32	33,5	47	10	44,5	5	M6x1	360,00
A40.H14	HSK-A 40	14	90	33,5	33,5	47	10	70	5	M6x1	360,00
A40.H16	HSK-A 40	16	90	38	50	52	10	38	5	M10x1	360,00
A40.H18	HSK-A 40	18	90	40	52	52	10	38	5	M10x1	360,00
A40.H20	HSK-A 40	20	90	42	54	52	10	38	5	M10x1	360,00
A50.H06	HSK-A 50	6	80	26	42	37	10	33	5	M6x1	370,00
A50.H08	HSK-A 50	8	80	28	42	37	10	33,5	5	M6x1	370,00
A50.H10	HSK-A 50	10	85	30	42	42	10	39	5	M8x1	370,00
A50.H12	HSK-A 50	12	90	32	42	47	10	44	5	M8x1	370,00
A50.H14	HSK-A 50	14	90	34	42	47	10	46	5	M10x1	370,00
A50.H16	HSK-A 50	16	95	38	42	52	10	51,5	5	M12x1	370,00
A50.H18	HSK-A 50	18	95	40	42	52	10	52	5	M12x1	370,00
A50.H20	HSK-A 50	20	100	42	42	52	10	74	5	M12x1	370,00
A50.H25	HSK-A 50	25	120	50	42	58	10	78	6	M12x1	390,00

LSCX = Einspannlänge, max.

LSCX = Clamping depth, max.

LSCX = Profondeur d'insertion, max.

ADJRGA = Verstellweg, max.

ADJRGA = Length adjustment range, max.

ADJRGA = Course de réglage, max.

Lieferumfang: Ohne Spannschlüssel

Delivery: Without wrench

Livraison: Sans clé de serrage

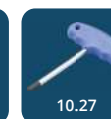
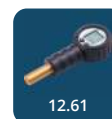



Hydraulic expansion chucks  
Mandrins expansibles hydrauliques



**Verwendung:**  
Zur Aufnahme von Werkzeugen mit Zylinderschaft nach DIN 1835 Form A+B+E und DIN 6535 Form HB+HE (größer Ø 20 mm nur mit Reduzierung).

**Application:**  
For mounting straight-shank tools acc. DIN 1835 form A+B+E and DIN 6535 form HB+HE (larger than Ø 20 mm only with reduction sleeve).

**Application:**  
Pour le serrage d'outils avec queue cylindrique suivant DIN 1835 forme A+B+E et DIN 6535 forme HB+HE (à partir de Ø 20 mm seulement avec réduction).

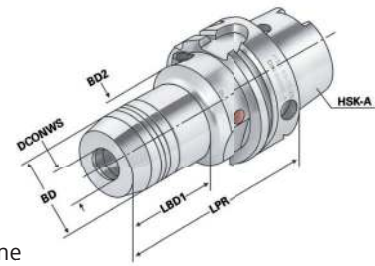

ISO 12164 Form A  $\leq 3\mu\text{m}$  G2.5 25.000 min<sup>-1</sup> RFID Chip

i 13.04

Bestell-Nr. Order no. Référence	HSK	DCONWS	LPR	BD	BD2	LSCX	ADJRGA	LBD1	DRVS	THID	EUR
A63.H06	HSK-A 63	6	80	26	50	37	10	33	5	M6x1	290,00
A63.H08	HSK-A 63	8	80	28	50	37	10	33,5	5	M6x1	290,00
A63.H10	HSK-A 63	10	85	30	50	42	10	39	5	M8x1	290,00
A63.H12	HSK-A 63	12	90	32	50	47	10	44,5	5	M8x1	290,00
A63.H14	HSK-A 63	14	90	34	50	47	10	46	5	M10x1	290,00
A63.H16	HSK-A 63	16	95	38	50	52	10	51,5	5	M12x1	290,00
A63.H18	HSK-A 63	18	95	40	50	52	10	52	5	M12x1	290,00
A63.H20	HSK-A 63	20	100	42	50	52	10	58	5	M10x1	290,00
A63.H25	HSK-A 63	25	120	50	50	58	10	94	6	M16x1	314,00
A63.H32	HSK-A 63	32	125	60	53	62	10	83	6	M16x1	314,00
A63.H06.1	HSK-A 63	6	150	26	50	37	10	103	5	M6x1	373,00
A63.H08.1	HSK-A 63	8	150	28	50	37	10	104	5	M6x1	373,00
A63.H10.1	HSK-A 63	10	150	30	50	42	10	104	5	M8x1	373,00
A63.H12.1	HSK-A 63	12	150	32	50	47	10	105	5	M8x1	373,00
A63.H14.1	HSK-A 63	14	150	34	50	47	10	105	5	M10x1	373,00
A63.H16.1	HSK-A 63	16	150	38	50	52	10	106,5	5	M12x1	373,00
A63.H18.1	HSK-A 63	18	150	40	50	52	10	107	5	M12x1	373,00
A63.H20.1	HSK-A 63	20	150	42	50	52	10	108	5	M10x1	373,00
A63.H25.1	HSK-A 63	25	150	50	50	58	10	124	6	M16x1	395,00
A63.H06.2	HSK-A 63	6	200	26	50	37	10	153	5	M6x1	519,00
A63.H08.2	HSK-A 63	8	200	28	50	37	10	154	5	M6x1	519,00
A63.H10.2	HSK-A 63	10	200	30	50	42	10	154	5	M8x1	519,00
A63.H12.2	HSK-A 63	12	200	32	50	47	10	155	5	M8x1	519,00
A63.H14.2	HSK-A 63	14	200	34	50	47	10	155	5	M10x1	519,00
A63.H16.2	HSK-A 63	16	200	38	50	52	10	156,5	5	M12x1	519,00
A63.H18.2	HSK-A 63	18	200	40	50	52	10	157	5	M12x1	519,00
A63.H20.2	HSK-A 63	20	200	42	50	52	10	158	5	M10x1	519,00
A63.H25.2	HSK-A 63	25	200	50	50	58	10	174	6	M16x1	539,00

LSCX = Einspannlänge, max.  
LSCX = Clamping depth, max.  
LSCX = Profondeur d'insertion, max.

ADJRGA = Verstellweg, max.  
ADJRGA = Length adjustment range, max.  
ADJRGA = Course de réglage, max.

Lieferumfang: Ohne Spannschlüssel  
Delivery: Without wrench  
Livraison: Sans clé de serrage





**Verwendung:**

Zur Aufnahme von Werkzeugen mit Zylinderschaft nach DIN 1835 Form A+B+E und DIN 6535 Form HB+HE (größer Ø 20 mm nur mit Reduzierung).

**Application:**

For mounting straight-shank tools acc. DIN 1835 form A+B+E and DIN 6535 form HB+HE (larger than Ø 20 mm only with reduction sleeve).

**Application:**

Pour le serrage d'outils avec queue cylindrique suivant DIN 1835 forme A+B+E et DIN 6535 forme HB+HE (à partir de Ø 20 mm seulement avec réduction).

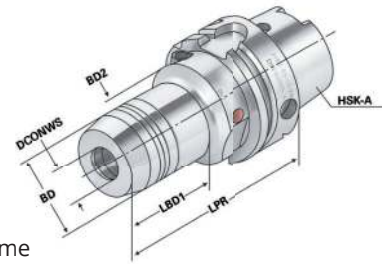

5

Bestell-Nr. Order no. Référence	HSK	DCONWS	LPR	BD	BD2	LSCX	ADJRGA	LBD1	DRVS	THID	EUR
A100.H06	HSK-A 100	6	85	26	63	37	10	33	5	M6x1	350,00
A100.H08	HSK-A 100	8	85	28	63	37	10	33,5	5	M6x1	350,00
A100.H10	HSK-A 100	10	90	30	63	42	10	39	5	M8x1	350,00
A100.H12	HSK-A 100	12	95	32	63	47	10	44,5	5	M8x1	350,00
A100.H14	HSK-A 100	14	95	34	63	47	10	46	5	M8x1	350,00
A100.H16	HSK-A 100	16	100	38	63	52	10	53	5	M12x1	350,00
A100.H18	HSK-A 100	18	100	40	63	52	10	52	5	M12x1	350,00
A100.H20	HSK-A 100	20	105	42	63	52	10	51	5	M12x1	350,00
A100.H25	HSK-A 100	25	115	50	63	58	10	64	6	M12x1	375,00
A100.H32	HSK-A 100	32	120	60	63	62	10	61	6	M12x1	375,00
A100.H06.1	HSK-A 100	6	150	26	63	37	10	97	5	M6	529,00
A100.H08.1	HSK-A 100	8	150	28	63	37	10	98	5	M6	529,00
A100.H10.1	HSK-A 100	10	150	30	63	42	10	99	5	M8x1	529,00
A100.H12.1	HSK-A 100	12	150	32	63	47	10	99	5	M8x1	529,00
A100.H14.1	HSK-A 100	14	150	34	63	47	10	101	5	M8x1	529,00
A100.H16.1	HSK-A 100	16	150	38	63	52	10	101	5	M12x1	529,00
A100.H18.1	HSK-A 100	18	150	40	63	52	10	102	5	M12x1	529,00
A100.H20.1	HSK-A 100	20	150	42	63	52	10	101	5	M12x1	529,00
A100.H25.1	HSK-A 100	25	150	50	63	58	10	99	6	M12x1	539,00
A100.H32.1	HSK-A 100	32	150	60	63	62	10	100	6	M12x1	549,00



**Spannkraft-Prüfgerät für Hydrodehnspannfutter - Seite 12.61**

Clamping force proofing instrument for hydraulic chucks - page 12.61

Appareil de contrôle des forces de serrage pour mandrin expansibles hydrauliques - page 12.61



LSCX = Einspannlänge, max.  
LSCX = Clamping depth, max.  
LSCX = Profondeur d'insertion, max.

ADJRGA = Verstellweg, max.  
ADJRGA = Length adjustment range, max.  
ADJRGA = Course de réglage, max.

Lieferumfang: Ohne Spannschlüssel  
Delivery: Without wrench  
Livraison: Sans clé de serrage



## Reparatur und Wartung für Hydro-Dehnspannfutter

Die Hydro-Dehnspanntechnik ist eine weltweit verbreitete, bewährte und zuverlässige Methode zur Aufnahme von Werkzeugen. Dank ihrer konstruktiven Vorteile ist sie unempfindlich, wartungsarm und langlebig. Dennoch kommt es durch thermische und mechanische Belastung im Werkstattgebrauch im Laufe der Zeit zu Spannkraftverlusten. Die Folge sind schlechtere Werkzeugstandzeiten und Qualitätseinbußen bei der Bearbeitung bis hin zum teuren Werkzeugbruch.

Wir warten und reparieren Ihre Hydro-Dehnspannfutter - egal ob von uns oder ein Fremdfabrikat - kostengünstig hier bei uns in Süd-Deutschland.

Hier prüfen wir die Ursachen für den Spannkraftverlust und reparieren innerhalb von zwei Wochen zu einem günstigen Festpreis. Wir erneuern dabei alle Verschleißteile, befüllen das Hydrauliksystem neu und justieren das Hydrauliksystem auf den korrekten Spanndruck. Abschließend erfolgt eine Endprüfung.

Kontaktieren Sie unseren Kundenservice für weitere Informationen und Preise.

## Maintenance and repair of hydraulic chucks

*Clamping of tools with hydraulic chucks is a widespread, well-established and reliable method. It is a resistant, easy-to-operate and durable way of clamping due to its advantageous construction design. Nevertheless in the course of time under the influence of thermal and mechanical outputs at factories loss of clamping force is observed. As a result the life of the tool shortens and its quality during the working process reduces. Therefore it leads to a costly damage of the tool.*

*We maintain and repair your hydraulic chucks - both those manufactured at our place and those produced somewhere else - for a reasonable price here at our office in the south of Germany.*

*We check possible causes of the clamping force reduction and repair it within two weeks at a fixed low price. At the same time we renew all the fast wearing parts, fill the hydraulic system anew and adjust its clamping force. Afterwards the final inspection stage takes place.*

*You are welcome to contact our customer service for further information and prices.*

5

## La réparation et la maintenance des mandrins hydrauliques

L'accueil des outils à l'aide d'un mandrin hydraulique est une technique éprouvée, répandue à l'échelle mondiale et de confiance. Grâce à sa construction avantageuse elle est robuste, facile à entretenir et durable. Pourtant à cause de la charge thermique et mécanique imposés sur les mandrins lors du travail la tension du ressort diminue au fil du temps. Par conséquent la résistance des outils coupants se détériore et la qualité lors d'usinage se réduit. En retour cela conduit à la rupture coûteuse d'outil.

On entretient et répare vos mandrins hydrauliques - peu importe l'issue de notre production ou d'ailleurs - bon marché et ici chez nous au sud de l'Allemagne.

Tout d'abord nos spécialistes cherchent la cause de la perte de la tension du ressort, ensuite ils effectuent la réparation sous 2 semaines pour le prix fixe et favorable. En outre ils renouvellent toutes les pièces d'usure, remplissent le système hydraulique à nouveau et ajustent la tension correcte. À la fin l'inspection finale se déroule.

Contactez notre centre de service client pour obtenir l'information supplémentaire ainsi que l'information actuelle sur le prix.





Shrink chucks 4,5° for mounting of solid carbide and HSS-tool shanks  
Mandrins de frettage 4,5° pour le serrage de queues d'outils carbures de type HM et HSS



**Verwendung:**  
Zur Aufnahme von Werkzeugen mit  
Zylinderschaft.  
**Application:**  
For mounting straight-shank tools.  
**Application:**  
Pour le serrage d'outils avec queue  
cylindrique.

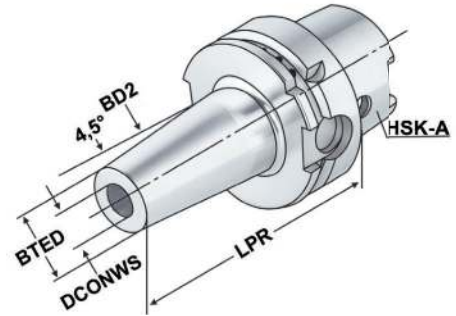

ISO 12164    Form A     $\leq 3\mu\text{m}$     G2,5 25.000 min<sup>-1</sup>    RFID Chip    h6

5

Bestell-Nr. Order no. Référence	HSK	DCONWS	TDCON	LPR	BTED	BD2	LSCN	LSCX	ADJRGA	THID	EUR
A32.70.03	HSK-A 32	3	h4	60	11	15	-	10	-	-	129,00
A32.70.04	HSK-A 32	4	h4	60	10	16	-	20	-	-	129,00
A32.70.05	HSK-A 32	5	h4	60	10	16	-	20	-	-	129,00
A32.70.06	HSK-A 32	6	h6	70	21	26	26	36	10	M5x0,8	111,00
A32.70.08	HSK-A 32	8	h6	70	21	26	26	36	10	M6x1	111,00
A32.70.10	HSK-A 32	10	h6	70	24	29	32	42	10	M8x1	111,00
A32.70.12	HSK-A 32	12	h6	90	24	29	37	47	10	M10x1	111,00
A32.70.14	HSK-A 32	14	h6	90	27	34	37	47	10	M10x1	111,00
A32.70.16	HSK-A 32	16	h6	90	27	34	40	50	10	M12x1	111,00
A32.70.20	HSK-A 32	20	h6	100	33	40	42	52	10	M12x1	111,00
A40.70.03	HSK-A 40	3	h4	80	11	15	-	10	-	-	131,00
A40.70.04	HSK-A 40	4	h4	80	14	22	-	20	-	-	131,00
A40.70.05	HSK-A 40	5	h4	80	16	22	-	20	-	-	131,00
A40.70.06	HSK-A 40	6	h6	80	21	27	26	36	10	M5x0,8	113,00
A40.70.08	HSK-A 40	8	h6	80	21	27	26	36	10	M6x1	113,00
A40.70.10	HSK-A 40	10	h6	80	24	32	32	42	10	M8x1	113,00
A40.70.12	HSK-A 40	12	h6	90	24	32	37	47	10	M10x1	113,00
A40.70.14	HSK-A 40	14	h6	90	27	34	37	47	10	M10x1	113,00
A40.70.16	HSK-A 40	16	h6	90	27	34	40	50	10	M12x1	113,00
A40.70.18	HSK-A 40	18	h6	95	33	42	40	50	10	M12x1	113,00
A40.70.20	HSK-A 40	20	h6	100	33	42	42	52	10	M16x1	113,00

LSCX = Einspannlänge, max.    ADJRGA = Verstellweg, max.  
LSCX = Clamping depth, max.    ADJRGA = Length adjustment range, max.  
LSCX = Profondeur d'insertion, max.    ADJRGA = Course de réglage, max.

**Für Ø 3, 4 und 5 mm nur Hartmetallschäfte verwenden!**  
For Ø 3, 4 and 5 mm only solid carbide tool shanks must be used!  
Pour Ø 3, 4 et 5 mm il faut seulement utiliser de queues d'outils carbures de type HM!

- Hinweis:** Aufnahme für Induktiv-, Kontakt- und Heißluftschumpfgeräte geeignet.  
Schafttoleranz bei Ø 3, 4 und 5 mm = h<sub>4</sub>, bei Ø 6 – Ø 32 mm = h<sub>6</sub>
- Note:** Toolholders suitable for induction-, contact- and hot air shrink units.  
Ø 3, 4, 5 with h<sub>4</sub>-tolerance and Ø 6 – Ø 32 with h<sub>6</sub>-tolerance
- Observation:** Porte-outils convenables pour machines à fretter par induction,  
par contact, ou par air chaud.  
Ø 3, 4, 5 avec h<sub>4</sub>-tolerance et Ø 6 – Ø 32 avec h<sub>6</sub>-tolerance



Shrink chucks 4,5° for mounting of solid carbide and HSS-tool shanks

Mandrins de frettage 4,5° pour le serrage de queues d'outils carbures de type HM et HSS



**Verwendung:**  
Zur Aufnahme von Werkzeugen mit Zylinderschaft.

**Application:**  
For mounting straight-shank tools.

**Application:**  
Pour le serrage d'outils avec queue cylindrique.

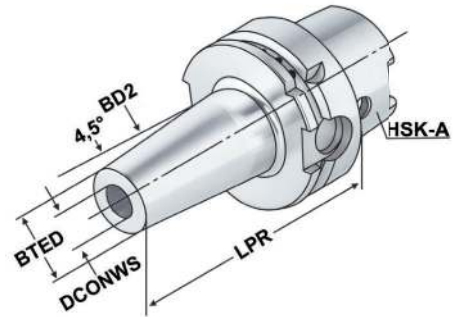

ISO 12164    Form A     $\leq 3\mu\text{m}$     G2.5 25.000 min<sup>-1</sup>    RFID Chip    h6

Bestell-Nr. Order no. Référence	HSK	DCONWS	TDCON	LPR	BTED	BD2	LSCN	LSCX	ADJRGA	THID	EUR
A50.70.03	HSK-A 50	3	h4	80	11	15	-	18	-	-	135,00
A50.70.04	HSK-A 50	4	h4	80	14	22	-	20	-	-	135,00
A50.70.05	HSK-A 50	5	h4	80	16	22	-	20	-	-	135,00
A50.70.06	HSK-A 50	6	h6	80	21	27	26	36	10	M5x0,8	119,00
A50.70.08	HSK-A 50	8	h6	80	21	27	26	36	10	M6x1	119,00
A50.70.10	HSK-A 50	10	h6	85	24	32	32	42	10	M8x1	119,00
A50.70.12	HSK-A 50	12	h6	90	24	32	37	47	10	M10x1	119,00
A50.70.14	HSK-A 50	14	h6	90	27	34	37	47	10	M10x1	119,00
A50.70.16	HSK-A 50	16	h6	95	27	34	40	50	10	M12x1	119,00
A50.70.18	HSK-A 50	18	h6	95	33	42	40	50	10	M12x1	119,00
A50.70.20	HSK-A 50	20	h6	100	33	42	42	52	10	M16x1	119,00

5







Shrink chucks 4,5° for mounting of solid carbide and HSS-tool shanks  
Mandrins de frettage 4,5° pour le serrage de queues d'outils carbures de type HM et HSS



**Verwendung:**  
Zur Aufnahme von Werkzeugen mit  
Zylinderschaft.  
**Application:**  
For mounting straight-shank tools.  
**Application:**  
Pour le serrage d'outils avec queue  
cylindrique.

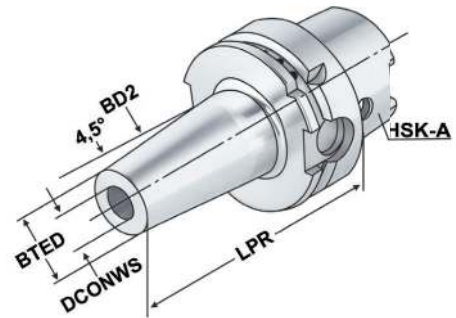

ISO 12164    Form A     $\leq 3\mu\text{m}$     G2,5 25.000 min<sup>-1</sup>    RFID Chip    h6

5

Bestell-Nr. Order no. Référence	HSK	DCONWS	TDCON	LPR	BTED	BD2	LSCN	LSCX	ADJRGA	THID	EUR
A63.70.03	HSK-A 63	3	h4	80	11	15	9	-	-	-	155,00
A63.70.04	HSK-A 63	4	h4	80	14	22	9	-	-	-	155,00
A63.70.05	HSK-A 63	5	h4	80	16	22	10	-	-	-	155,00
A63.70.06	HSK-A 63	6	h6	80	21	27	22	36	10	M5x0,8	136,00
A63.70.08	HSK-A 63	8	h6	80	21	27	26	36	10	M6x1	136,00
A63.70.10	HSK-A 63	10	h6	85	24	32	31	41	10	M8x1	136,00
A63.70.12	HSK-A 63	12	h6	90	24	32	36	46	10	M10x1	136,00
A63.70.14	HSK-A 63	14	h6	90	27	34	36	46	10	M10x1	136,00
A63.70.16	HSK-A 63	16	h6	95	27	34	39	49	10	M12x1	136,00
A63.70.18	HSK-A 63	18	h6	95	33	42	39	49	10	M12x1	136,00
A63.70.20	HSK-A 63	20	h6	100	33	42	41	51	10	M16x1	136,00
A63.70.25	HSK-A 63	25	h6	115	44	53	47	57	10	M16x1	136,00
A63.70.32	HSK-A 63	32	h6	120	44	53	51	61	10	M16x1	136,00
A63.70.03.1	HSK-A 63	3	h4	120	11	15	9	-	-	-	175,00
A63.70.04.1	HSK-A 63	4	h4	120	14	22	9	-	-	-	175,00
A63.70.05.1	HSK-A 63	5	h4	120	16	22	10	-	-	-	175,00
A63.70.06.1	HSK-A 63	6	h6	120	21	27	22	36	10	M5x0,8	155,00
A63.70.08.1	HSK-A 63	8	h6	120	21	27	26	36	10	M6x1	155,00
A63.70.10.1	HSK-A 63	10	h6	120	24	32	31	41	10	M8x1	155,00
A63.70.12.1	HSK-A 63	12	h6	120	24	32	36	46	10	M10x1	155,00
A63.70.14.1	HSK-A 63	14	h6	120	27	34	36	46	10	M10x1	155,00
A63.70.16.1	HSK-A 63	16	h6	120	27	34	39	49	10	M12x1	155,00
A63.70.18.1	HSK-A 63	18	h6	120	33	42	39	49	10	M12x1	155,00
A63.70.20.1	HSK-A 63	20	h6	120	33	42	41	51	10	M16x1	155,00

Für Ø 3, 4 und 5 mm nur Hartmetallschäfte verwenden!  
For Ø 3, 4 and 5 mm only solid carbide tool shanks must be used!  
Pour Ø 3, 4 et 5 mm il faut seulement utiliser de queues d'outils carbures de type HM!

- Hinweis:** Aufnahme für Induktiv-, Kontakt- und Heißluftschumpfergeräte geeignet.  
Schafttoleranz bei Ø 3, 4 und 5 mm = h<sub>4</sub>, bei Ø 6 - Ø 32 mm = h<sub>6</sub>
- Note:** Toolholders suitable for induction-, contact- and hot air shrink units.  
Ø 3, 4, 5 with h<sub>4</sub>-tolerance and Ø 6 - Ø 32 with h<sub>6</sub>-tolerance
- Observation:** Porte-outils convenables pour machines à fretter par induction,  
par contact, ou par air chaud.  
Ø 3, 4, 5 avec h<sub>4</sub>-tolerance et Ø 6 - Ø 32 avec h<sub>6</sub>-tolerance

LSCX = Einspannlänge, max.    ADJRGA = Verstellweg, max.  
LSCX = Clamping depth, max.    ADJRGA = Length adjustment range, max.  
LSCX = Profondeur d'insertion, max.    ADJRGA = Course de réglage, max.



Shrink chucks 4,5° for mounting of solid carbide and HSS-tool shanks

Mandrins de frettage 4,5° pour le serrage de queues d'outils carbures de type HM et HSS



**Verwendung:**  
Zur Aufnahme von Werkzeugen mit Zylinderschaft.  
**Application:**  
For mounting straight-shank tools.  
**Application:**  
Pour le serrage d'outils avec queue cylindrique.

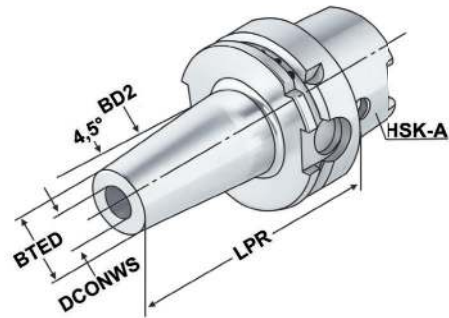

ISO 12164 Form A  $\leq 3\mu\text{m}$  G2.5 25.000 min<sup>-1</sup> RFID Chip h6

Bestell-Nr. Order no. Référence	HSK	DCONWS	TDCON	LPR	BTED	BD2	LSCN	LSCX	ADJRGA	THID	EUR
A63.70.03.2	HSK-A 63	3	h4	160	11	15	9	-	-	-	224,00
A63.70.04.2	HSK-A 63	4	h4	160	14	22	9	-	-	-	224,00
A63.70.05.2	HSK-A 63	5	h4	160	16	22	10	-	-	-	224,00
A63.70.06.2	HSK-A 63	6	h6	160	21	27	22	36	10	M5x0,8	203,00
A63.70.08.2	HSK-A 63	8	h6	160	21	27	26	36	10	M6x1	203,00
A63.70.10.2	HSK-A 63	10	h6	160	24	32	31	41	10	M8x1	203,00
A63.70.12.2	HSK-A 63	12	h6	160	24	32	36	46	10	M10x1	203,00
A63.70.14.2	HSK-A 63	14	h6	160	27	34	36	46	10	M10x1	203,00
A63.70.16.2	HSK-A 63	16	h6	160	27	34	39	49	10	M12x1	203,00
A63.70.18.2	HSK-A 63	18	h6	160	33	42	39	49	10	M12x1	203,00
A63.70.20.2	HSK-A 63	20	h6	160	33	42	41	51	10	M16x1	203,00
A63.70.25.2	HSK-A 63	25	h6	160	44	53	47	57	10	M16x1	203,00
A63.70.32.2	HSK-A 63	32	h6	160	44	53	51	61	10	M16x1	203,00
A63.70.06.3	HSK-A 63	6	h6	200	21	27	22	36	10	M5x0,8	230,00
A63.70.08.3	HSK-A 63	8	h6	200	21	27	26	36	10	M6x1	230,00
A63.70.10.3	HSK-A 63	10	h6	200	24	32	31	41	10	M8x1	230,00
A63.70.12.3	HSK-A 63	12	h6	200	24	32	36	46	10	M10x1	230,00
A63.70.14.3	HSK-A 63	14	h6	200	27	34	36	46	10	M10x1	230,00
A63.70.16.3	HSK-A 63	16	h6	200	27	34	39	49	10	M12x1	230,00
A63.70.18.3	HSK-A 63	18	h6	200	33	42	39	49	10	M12x1	230,00
A63.70.20.3	HSK-A 63	20	h6	200	33	42	41	51	10	M16x1	230,00
A63.70.25.3	HSK-A 63	25	h6	200	44	53	47	57	10	M16x1	230,00
A63.70.32.3	HSK-A 63	32	h6	200	44	53	51	61	10	M16x1	230,00

5

Für Ø 3, 4 und 5 mm nur Hartmetallschäfte verwenden!

For Ø 3, 4 and 5 mm only solid carbide tool shanks must be used!

Pour Ø 3, 4 et 5 mm il faut seulement utiliser de queues d'outils carbures de type HM!

**Hinweis:** Aufnahme für Induktiv-, Kontakt- und Heißluftschrimpfergeräte geeignet.  
Schafttoleranz bei Ø 3, 4 und 5 mm = h<sub>4</sub>, bei Ø 6 - Ø 32 mm = h<sub>6</sub>

**Note:** Toolholders suitable for induction-, contact- and hot air shrink units.  
Ø 3, 4, 5 with h<sub>4</sub>-tolerance and Ø 6 - Ø 32 with h<sub>6</sub>-tolerance

**Observation:** Porte-outils convenables pour machines à fretter par induction, par contact, ou par air chaud.  
Ø 3, 4, 5 avec h<sub>4</sub>-tolerance et Ø 6 - Ø 32 avec h<sub>6</sub>-tolerance



LSCN = Einspannlänge, max.  
LSCX = Clamping depth, max.  
LSCX = Profondeur d'insertion, max.

ADJRGA = Verstellweg, max.  
ADJRGA = Length adjustment range, max.  
ADJRGA = Course de réglage, max.



Shrink chucks 4,5° for mounting of solid carbide and HSS-tool shanks

Mandrins de frettage 4,5° pour le serrage de queues d'outils carbures de type HM et HSS

**Verwendung:**

Zur Aufnahme von Werkzeugen mit Zylinderschaft.

**Application:**

For mounting straight-shank tools.

**Application:**

Pour le serrage d'outils avec queue cylindrique.

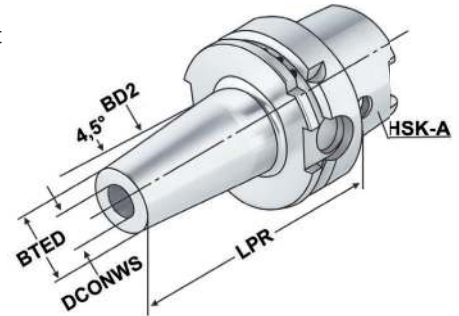
ISO  
12164Form  
ARFID  
Chip

h6

5

Bestell-Nr. Order no. Référence	HSK	DCONWS	TDCON	LPR	BTED	BD2	LSCN	LSCX	ADJRGA	THID	EUR
A100.70.04	HSK-A 100	4	h4	85	14	22	8	-	-	-	219,00
A100.70.05	HSK-A 100	5	h4	85	16	22	10	-	-	-	219,00
A100.70.06	HSK-A 100	6	h6	85	21	27	22	36	10	M5x0,8	205,00
A100.70.08	HSK-A 100	8	h6	85	21	27	26	36	10	M6x1	205,00
A100.70.10	HSK-A 100	10	h6	90	24	32	31	41	10	M8x1	205,00
A100.70.12	HSK-A 100	12	h6	95	24	32	36	46	10	M10x1	205,00
A100.70.14	HSK-A 100	14	h6	95	27	34	36	46	10	M10x1	205,00
A100.70.16	HSK-A 100	16	h6	100	27	34	39	49	10	M12x1	205,00
A100.70.18	HSK-A 100	18	h6	100	33	42	39	49	10	M12x1	205,00
A100.70.20	HSK-A 100	20	h6	105	33	42	41	51	10	M16x1	205,00
A100.70.25	HSK-A 100	25	h6	120	44	53	47	57	10	M16x1	225,00
A100.70.32	HSK-A 100	32	h6	120	44	53	51	61	10	M16x1	235,00
A100.70.06.1	HSK-A 100	6	h6	120	21	27	22	36	10	M5x0,8	225,00
A100.70.08.1	HSK-A 100	8	h6	120	21	27	26	36	10	M6x1	225,00
A100.70.10.1	HSK-A 100	10	h6	120	24	32	31	41	10	M8x1	225,00
A100.70.12.1	HSK-A 100	12	h6	120	24	32	36	46	10	M10x1	225,00
A100.70.14.1	HSK-A 100	14	h6	120	27	34	36	46	10	M10x1	225,00
A100.70.16.1	HSK-A 100	16	h6	120	27	34	39	49	10	M12x1	225,00
A100.70.18.1	HSK-A 100	18	h6	120	33	42	39	49	10	M12x1	225,00
A100.70.20.1	HSK-A 100	20	h6	120	33	42	41	51	10	M16x1	225,00
A100.70.06.2	HSK-A 100	6	h6	160	21	27	22	36	10	M5x0,8	238,00
A100.70.08.2	HSK-A 100	8	h6	160	21	27	26	36	10	M6x1	238,00
A100.70.10.2	HSK-A 100	10	h6	160	24	32	31	41	10	M8x1	238,00
A100.70.12.2	HSK-A 100	12	h6	160	24	32	36	46	10	M10x1	238,00
A100.70.14.2	HSK-A 100	14	h6	160	27	34	36	46	10	M10x1	238,00
A100.70.16.2	HSK-A 100	16	h6	160	27	34	39	49	10	M12x1	238,00
A100.70.18.2	HSK-A 100	18	h6	160	33	42	39	49	10	M12x1	238,00
A100.70.20.2	HSK-A 100	20	h6	160	33	42	41	51	10	M16x1	238,00
A100.70.25.2	HSK-A 100	25	h6	160	44	53	47	57	10	M16x1	238,00
A100.70.32.2	HSK-A 100	32	h6	160	44	53	51	61	10	M16x1	238,00



10.84



5.51

Shrink chucks 4,5° for mounting of solid carbide and HSS-tool shanks

Mandrins de frettage 4,5° pour le serrage de queues d'outils carbures de type HM et HSS



**Verwendung:**  
Zur Aufnahme von Werkzeugen mit Zylinderschaft.

**Application:**  
For mounting straight-shank tools.

**Application:**  
Pour le serrage d'outils avec queue cylindrique.

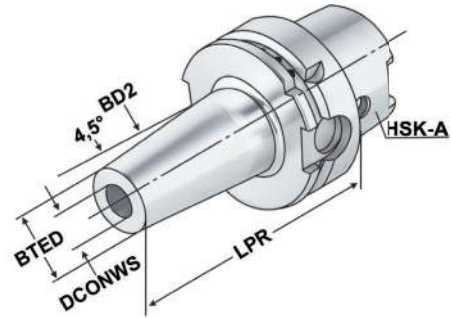

ISO 12164	Form A	≤ 3µm	G2.5 25.000 min <sup>-1</sup>	RFID Chip	h6
-----------	--------	-------	-------------------------------	-----------	----

Bestell-Nr. Order no. Référence	HSK	DCONWS	TDCON	LPR	BTED	BD2	LSCN	LSCX	ADJRGA	THID	EUR
A100.70.06.3	HSK-A 100	6	h6	200	21	27	22	36	10	M5x0,8	265,00
A100.70.08.3	HSK-A 100	8	h6	200	21	27	26	36	10	M6x1	265,00
A100.70.10.3	HSK-A 100	10	h6	200	24	32	31	41	10	M8x1	265,00
A100.70.12.3	HSK-A 100	12	h6	200	24	32	36	46	10	M10x1	265,00
A100.70.14.3	HSK-A 100	14	h6	200	27	34	36	46	10	M10x1	265,00
A100.70.16.3	HSK-A 100	16	h6	200	27	34	39	49	10	M12x1	265,00
A100.70.18.3	HSK-A 100	18	h6	200	33	42	39	49	10	M12x1	265,00
A100.70.20.3	HSK-A 100	20	h6	200	33	42	41	51	10	M16x1	265,00
A100.70.25.3	HSK-A 100	25	h6	200	44	53	47	57	10	M16x1	265,00
A100.70.32.3	HSK-A 100	32	h6	200	44	53	51	61	10	M16x1	265,00

5

LSCX = Einspannlänge, max.      ADJRGA = Verstellweg, max.  
LSCX = Clamping depth, max.    ADJRGA = Length adjustment range, max.  
LSCX = Profondeur d'insertion, max.    ADJRGA = Course de réglage, max.

**Für Ø 3, 4 und 5 mm nur Hartmetallschäfte verwenden!**  
For Ø 3, 4 and 5 mm only solid carbide tool shanks must be used!  
Pour Ø 3, 4 et 5 mm il faut seulement utiliser de queues d'outils carbures de type HM!

- Hinweis:** Aufnahme für Induktiv-, Kontakt- und Heißluftschumpfergeräte geeignet.  
Schafttoleranz bei Ø 3, 4 und 5 mm = h<sub>4</sub>, bei Ø 6 - Ø 32 mm = h<sub>6</sub>
- Note:** Toolholders suitable for induction-, contact- and hot air shrink units.  
Ø 3, 4, 5 with h<sub>4</sub>-tolerance and Ø 6 - Ø 32 with h<sub>6</sub>-tolerance
- Observation:** Porte-outils convenables pour machines à fretter par induction, par contact, ou par air chaud.  
Ø 3, 4, 5 avec h<sub>4</sub>-tolerance et Ø 6 - Ø 32 avec h<sub>6</sub>-tolerance

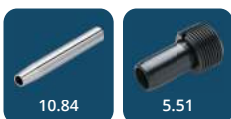



Shrink chucks 4,5° for mounting of solid carbide and HSS-tool shanks

Mandrins de frettage 4,5° pour le serrage de queues d'outils carbures de type HM et HSS

**Verwendung:**

Zur Aufnahme von Werkzeugen mit Zylinderschaft.

**Application:**

For mounting straight-shank tools.

**Application:**

Pour le serrage d'outils avec queue cylindrique.

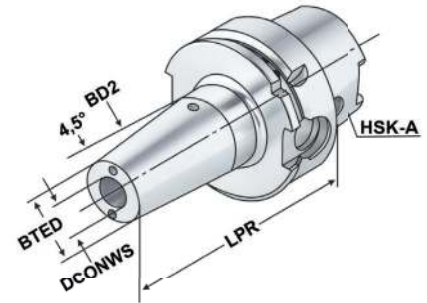

5

Bestell-Nr. Order no. Référence	HSK	DCONWS	TDCON	LPR	BTED	BD2	LSCN	LSCX	ADJRGA	THID	EUR
A63.70.03.K	HSK-A 63	3	h4	80	11	15	9	-	-	-	183,00
A63.70.04.K	HSK-A 63	4	h4	80	14	22	9	-	-	-	183,00
A63.70.05.K	HSK-A 63	5	h6	80	16	22	10	-	-	-	183,00
A63.70.06.K	HSK-A 63	6	h6	80	21	27	22	36	10	M5x0,8	173,00
A63.70.08.K	HSK-A 63	8	h6	80	21	27	26	36	10	M6x1	173,00
A63.70.10.K	HSK-A 63	10	h6	85	24	32	31	41	10	M8x1	173,00
A63.70.12.K	HSK-A 63	12	h6	90	24	32	36	46	10	M10x1	173,00
A63.70.14.K	HSK-A 63	14	h6	90	27	34	36	46	10	M10x1	173,00
A63.70.16.K	HSK-A 63	16	h6	95	27	34	39	49	10	M12x1	173,00
A63.70.18.K	HSK-A 63	18	h6	95	33	42	39	49	10	M12x1	173,00
A63.70.20.K	HSK-A 63	20	h6	100	33	42	41	51	10	M16x1	173,00
A63.70.25.K	HSK-A 63	25	h6	115	44	53	48	58	10	M16x1	184,00
A63.70.32.K	HSK-A 63	32	h6	120	44	53	51	61	10	M16x1	195,00
A63.70.03.1.K	HSK-A 63	3	h6	120	11	15	-	-	-	-	203,00
A63.70.04.1.K	HSK-A 63	4	h6	120	14	22	-	-	-	-	203,00
A63.70.05.1.K	HSK-A 63	5	h6	120	16	22	-	-	-	-	203,00
A63.70.06.1.K	HSK-A 63	6	h6	120	21	27	22	36	10	M5x0,8	188,00
A63.70.08.1.K	HSK-A 63	8	h6	120	21	27	26	36	10	M6x1	188,00
A63.70.10.1.K	HSK-A 63	10	h6	120	24	32	31	41	10	M8x1	188,00
A63.70.12.1.K	HSK-A 63	12	h6	120	24	32	36	46	10	M10x1	188,00
A63.70.14.1.K	HSK-A 63	14	h6	120	27	34	36	46	10	M10x1	188,00
A63.70.16.1.K	HSK-A 63	16	h6	120	27	34	39	49	10	M12x1	188,00
A63.70.18.1.K	HSK-A 63	18	h6	120	33	42	39	49	10	M12x1	188,00
A63.70.20.1.K	HSK-A 63	20	h6	120	33	42	41	51	10	M16x1	188,00

LSCX = Einspannlänge, max.

LSCX = Clamping depth, max.

LSCX = Profondeur d'insertion, max.

ADJRGA = Verstellweg, max.

ADJRGA = Length adjustment range, max.

ADJRGA = Course de réglage, max.

**Für Ø 3, 4 und 5 mm nur Hartmetallschäfte verwenden!**

For Ø 3, 4 and 5 mm only solid carbide tool shanks must be used!

Pour Ø 3, 4 et 5 mm il faut seulement utiliser de queues d'outils carbures de type HM!

**Hinweis:** Aufnahme für Induktiv-, Kontakt- und Heißluftschumpfgeräte geeignet. Schafttoleranz bei Ø 3, 4 und 5 mm = h<sub>4</sub>, bei Ø 6 - Ø 32 mm = h<sub>6</sub>**Note:** Toolholders suitable for induction-, contact- and hot air shrink units. Ø 3, 4, 5 with h<sub>4</sub>-tolerance and Ø 6 - Ø 32 with h<sub>6</sub>-tolerance**Observation:** Porte-outils convenables pour machines à fretter par induction, par contact, ou par air chaud. Ø 3, 4, 5 avec h<sub>4</sub>-tolerance et Ø 6 - Ø 32 avec h<sub>6</sub>-tolerance

**Shrink chucks 4,5° for mounting of solid carbide and HSS-tool shanks**  
**Mandrins de frettage 4,5° pour le serrage de queues d'outils carbures de type HM et HSS**



**Verwendung:**  
Zur Aufnahme von Werkzeugen mit  
Zylinderschaft.  
**Application:**  
For mounting straight-shank tools.  
**Application:**  
Pour le serrage d'outils avec queue  
cylindrique.

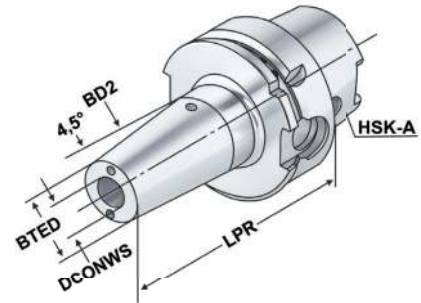

Bestell-Nr. Order no. Référence	HSK	DCONWS	TDCON	LPR	BTED	BD2	LSCN	LSCX	ADJRGA	THID	EUR
A63.70.06.2.K	HSK-A 63	6	h6	160	21	27	26	36	10	M5x0,8	219,00
A63.70.08.2.K	HSK-A 63	8	h6	160	21	27	26	36	10	M6x1	219,00
A63.70.10.2.K	HSK-A 63	10	h6	160	24	32	41	42	10	M8x1	219,00
A63.70.12.2.K	HSK-A 63	12	h6	160	24	32	37	47	10	M10x1	219,00
A63.70.14.2.K	HSK-A 63	14	h6	160	27	34	37	47	10	M10x1	219,00
A63.70.16.2.K	HSK-A 63	16	h6	160	27	34	40	50	10	M12x1	219,00
A63.70.18.2.K	HSK-A 63	18	h6	160	33	42	40	50	10	M12x1	219,00
A63.70.20.2.K	HSK-A 63	20	h6	160	33	42	42	52	10	M16x1	219,00
A63.70.25.2.K	HSK-A 63	25	h6	160	44	53	48	58	10	M16x1	219,00
A63.70.32.2.K	HSK-A 63	32	h6	160	44	53	51	61	10	M16x1	219,00
A100.70.06.K	HSK-A 100	6	h6	80	21	27	26	36	10	M5x0,8	214,00
A100.70.08.K	HSK-A 100	8	h6	80	21	27	26	36	10	M6x1	214,00
A100.70.10.K	HSK-A 100	10	h6	85	24	32	41	42	10	M8x1	214,00
A100.70.12.K	HSK-A 100	12	h6	90	24	32	46	47	10	M10x1	214,00
A100.70.14.K	HSK-A 100	14	h6	90	27	34	46	47	10	M10x1	214,00
A100.70.16.K	HSK-A 100	16	h6	95	27	34	40	50	10	M12x1	214,00
A100.70.18.K	HSK-A 100	18	h6	95	33	42	40	50	10	M12x1	214,00
A100.70.20.K	HSK-A 100	20	h6	100	33	42	42	52	10	M16x1	214,00
A100.70.25.K	HSK-A 100	25	h6	120	44	53	48	58	10	M16x1	214,00
A100.70.32.K	HSK-A 100	32	h6	120	44	53	51	61	10	M16x1	214,00
A100.70.06.1.K	HSK-A 100	6	h6	120	21	27	26	36	10	M5x0,8	255,00
A100.70.08.1.K	HSK-A 100	8	h6	120	21	27	26	36	10	M6x1	255,00
A100.70.10.1.K	HSK-A 100	10	h6	120	24	32	42	42	10	M8x1	255,00
A100.70.12.1.K	HSK-A 100	12	h6	120	24	32	37	47	10	M10x1	255,00
A100.70.14.1.K	HSK-A 100	14	h6	120	27	34	37	47	10	M10x1	255,00
A100.70.16.1.K	HSK-A 100	16	h6	120	27	34	40	50	10	M12x1	255,00
A100.70.18.1.K	HSK-A 100	18	h6	120	33	42	40	50	10	M12x1	255,00
A100.70.20.1.K	HSK-A 100	20	h6	120	33	42	42	52	10	M16x1	255,00

5





*Shrink chucks 3° for mounting of solid carbide and HSS-tool shanks - slim*  
Mandrins de frettage 3° pour le serrage de queues d'outils carbures de type HM et HSS - élancé



**Verwendung:**  
Zur Aufnahme von Werkzeugen mit Zylinderschaft.  
**Application:**  
For mounting straight-shank tools.  
**Application:**  
Pour le serrage d'outils avec queue cylindrique.

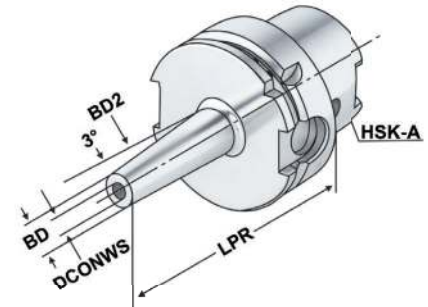

5

Bestell-Nr. Order no. Référence	HSK	DCONWS	TDCON	LPR	BTED	BD2	LSCN	LSCX	ADJRGA	THID	EUR
A63.72.03	HSK-A 63	3	h4	80	9	15,5	6	-	-	-	167,00
A63.72.04	HSK-A 63	4	h4	80	10	16,5	8	-	-	-	167,00
A63.72.05	HSK-A 63	5	h4	80	11	17,5	10	-	-	-	167,00
A63.72.06	HSK-A 63	6	h6	80	12	18,5	22	36	10	M5x0,8	146,00
A63.72.08	HSK-A 63	8	h6	80	14	20,5	26	36	10	M6x1	146,00
A63.72.10	HSK-A 63	10	h6	80	16	22,5	31	41	10	M8x1	146,00
A63.72.12	HSK-A 63	12	h6	80	18	24,5	36	46	10	M10x1	146,00
A63.72.03.1	HSK-A 63	3	h4	120	9	19,5	6	-	-	-	202,00
A63.72.04.1	HSK-A 63	4	h4	120	10	20,5	8	-	-	-	202,00
A63.72.05.1	HSK-A 63	5	h4	120	11	21,5	10	-	-	-	202,00
A63.72.06.1	HSK-A 63	6	h6	120	12	22,5	22	36	10	M5x0,8	176,00
A63.72.08.1	HSK-A 63	8	h6	120	14	24,5	26	36	10	M6x1	176,00
A63.72.10.1	HSK-A 63	10	h6	120	16	26,5	31	41	10	M8x1	176,00
A63.72.12.1	HSK-A 63	12	h6	120	18	28,5	36	46	10	M10x1	176,00
A63.72.04.2	HSK-A 63	4	h4	160	10	24	8	-	-	-	241,00
A63.72.05.2	HSK-A 63	5	h4	160	11	25	10	-	-	-	241,00
A63.72.06.2	HSK-A 63	6	h6	160	12	26,5	22	36	10	M5x0,8	220,00
A63.72.08.2	HSK-A 63	8	h6	160	14	28,5	26	36	10	M6x1	220,00
A63.72.10.2	HSK-A 63	10	h6	160	16	30,5	31	41	10	M8x1	220,00
A63.72.12.2	HSK-A 63	12	h6	160	18	32,5	36	46	10	M10x1	220,00

LSCX = Einspannlänge, max.      ADJRGA = Verstellweg, max.  
LSCX = Clamping depth, max.    ADJRGA = Length adjustment range, max.  
LSCX = Profondeur d'insertion, max.    ADJRGA = Course de réglage, max.

**Ausführung:** schlanke Bauform (reduzierte Störkontur)  
**Version:** slim design (reduced interference contour)  
**Version:** Modèle très étroit (encombrement réduit)

**Für Ø 3, 4 und 5 mm nur Hartmetallschäfte verwenden!**  
*For Ø 3, 4 and 5 mm only solid carbide tool shanks must be used!*  
Pour Ø 3, 4 et 5 mm il faut seulement utiliser de queues d'outils carbures de type HM!

**Hinweis:** Aufnahmen für Induktiv-, Kontakt- und Heißluftschumpfgeräte geeignet.  
Schafftoleranz bei Ø 3, 4 und 5 mm = h<sub>4</sub>, bei Ø 6 - Ø 32 mm = h<sub>6</sub>

**Note:** Toolholders suitable for induction-, contact- and hot air shrink units.  
Ø 3, 4, 5 with h<sub>4</sub>-tolerance and Ø 6 - Ø 32 with h<sub>6</sub>-tolerance

**Observation:** Porte-outils convenables pour machines à fretter par induction,  
par contact, ou par air chaud.  
Ø 3, 4, 5 avec h<sub>4</sub>-tolerance et Ø 6 - Ø 32 avec h<sub>6</sub>-tolerance



Shrink fit extensions 4,5°  
Rallonges de frettage 4,5°

**Verwendung:**  
Zum Einsatz in Schrumpffutter,  
Hydro-Dehnspannfutter und  
ER-Spannzangenfutter.

**Application:**  
For use in shrink-fit chucks, hydraulic  
chucks, and ER collet chucks.

**Application:**  
Pour mandrins de frettage, mandrins  
expansibles hydrauliques et man-  
drins à pince ER.

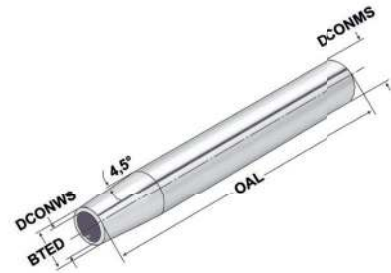

Bestell-Nr. Order no. Référence	DCONMS	DCONWS	BTED	OAL	LSCN	LSCX	ADJRGA	THID	EUR
120.70.03*	20	3	10	150	6	-	-	-	95,00
120.70.04*	20	4	10	150	8	-	-	-	95,00
120.70.05*	20	5	10	150	10	-	-	-	95,00
120.70.06	20	6	10	150	22	36	10	M5x0,8	95,00
120.70.08	20	8	12	150	26	36	10	M6x1	95,00
120.70.10	20	10	14	150	31	41	10	M8x1	95,00
120.70.12	20	12	16	150	36	46	10	M10x1	95,00
120.70.25.08	25	8	12	150	26	36	10	M6x1	129,00
120.70.25.10	25	10	14	150	31	41	10	M8x1	129,00
120.70.25.12	25	12	16	150	36	46	10	M10x1	129,00
120.70.25.14	25	14	18	150	36	46	10	M10x1	129,00
120.70.25.16	25	16	20	150	39	49	10	M12x1	129,00
120.70.32.10	32	10	14	150	31	41	10	M8x1	151,00
120.70.32.12	32	12	16	150	36	46	10	M10x1	151,00
120.70.32.14	32	14	18	150	36	46	10	M10x1	151,00
120.70.32.16	32	16	20	150	39	49	10	M12x1	151,00
120.70.32.18	32	18	22	150	39	49	10	M12x1	151,00
120.70.32.20	32	20	24	150	41	51	10	M16x1	151,00

5

\* ohne Anschlag | \* without end stop | \* sans butée

**Durchgangsbohrung für Innenkühlung vorhanden.**

Through hole for internal cooling provided.

Trou débouchant disponible pour arrosage interne.

LSCX = Einspannlänge, max.

LSCX = Clamping depth, max.

LSCX = Profondeur d'insertion, max.

ADJRGA = Verstellweg, max.

ADJRGA = Length adjustment range, max.

ADJRGA = Course de réglage, max.

**Für Ø 3, 4 und 5 mm nur Hartmetallschäfte verwenden!**

For Ø 3, 4 and 5 mm only solid carbide tool shanks must be used!

Pour Ø 3, 4 et 5 mm il faut seulement utiliser de queues d'outils carbures de type HM!

**Hinweis:** Aufnahmen für Induktiv-, Kontakt- und Heißluftschumpfergeräte geeignet.  
Schafttoleranz bei Ø 3, 4 und 5 mm = h<sub>4</sub>, bei Ø 6 - Ø 32 mm = h<sub>6</sub>

**Note:** Toolholders suitable for induction-, contact- and hot air shrink units.  
Ø 3, 4, 5 with h<sub>4</sub>-tolerance and Ø 6 - Ø 32 with h<sub>6</sub>-tolerance

**Remarque:** Porte-outils convenables pour machines à fretter par induction,  
par contact, ou par air chaud.  
Ø 3, 4, 5 avec h<sub>4</sub>-tolerance et Ø 6 - Ø 32 avec h<sub>6</sub>-tolerance





**Verwendung:**  
Zur Abnahme von Werkzeugmaschinen gemäß ISO-Empfehlung R230 oder zur Überprüfung der Werkzeugspindel.

**Application:**  
For the inspection of machine tools according to ISO recommendation R230 or for testing the tool spindle.

**Application:**  
Pour l'inspection de machine-outils suite à la recommandation ISO R230 ou pour la vérification de la broche.

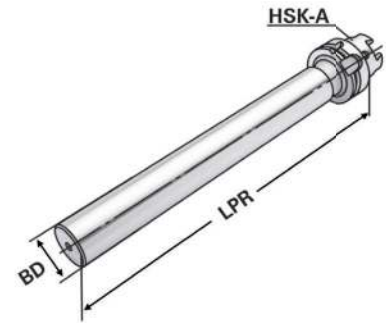

ISO 12164	Form A	 ≤ 3µm
--------------	-----------	-----------

5

Bestell-Nr. Order no. Référence	HSK	BD	LPR	Toleranz Tolerance Tolérance	max. Rundlaufabweichung max. concentricity deviation Faux-rond max.	EUR
A32.18.25	HSK-A 32	25	200	0,003	0,003	392,00
A40.18.25	HSK-A 40	25	200	0,003	0,003	414,00
A50.18.32	HSK-A 50	32	346	0,003	0,003	423,00
A63.18.40	HSK-A 63	40	346	0,003	0,003	410,00
A100.18.50	HSK-A 100	50	329	0,003	0,003	450,00

**Lieferumfang:** Auslieferung mit Prüfprotokoll  
**Delivery:** Delivery with test certificate  
**Livraison:** Livraison avec rapport d'essais

**Holzkasten für Kontrolldorne**  
Wooden box for test arbors  
Coffret en bois pour mandrins de contrôle



**Verwendung:**  
Zur Aufbewahrung von Kontrolldornen.

**Application:**  
For the storage of test arbors.

**Application:**  
Pour la conservation de mandrins de contrôle.



Bestell-Nr. Order no. Référence	Abmessung Size Dimension	für Kegelgrößen for cones pour cônes	EUR
701.18	460×130×115	SK 30 / 40 / 50	96,00

Key for coolant tubes  
Clés pour canules de lubrification



**Verwendung:**  
Zum Montieren der Kühlmittelübergabe-  
einheiten in HSK-Werkzeugaufnahmen.

**Application:**  
*For mounting the coolant tubes in HSK  
toolholders.*

**Application:**  
Pour le montage de canules de lubrifica-  
tion dans des porte-outils HSK.

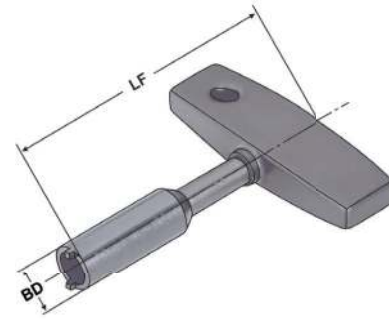
ISO  
12164Form  
A

Bestell-Nr. Order no. Référence	HSK	BD	LF	EUR
A32.701	HSK 32	8,5	115	25,00
A40.701	HSK 40	10,5	115	25,00
A50.701	HSK 50	14,5	115	25,00
A63.701	HSK 63	16,5	136	21,00
A80.701	HSK 80	18,5	136	27,00
A100.701	HSK 100	22,0	136	24,00

5



5.51



**Verwendung:**  
Zur zentralen Übergabe von Kühlmittel bei HSK-Werkzeugaufnahmen.  
**Application:**  
For the coolant supply through the centre of HSK toolholders.  
**Application:**  
Pour l'arrosage centrale de porte-outils HSK.

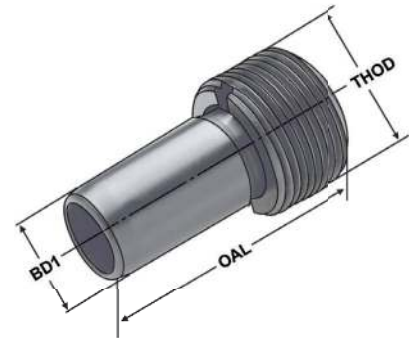

DIN  
69895

Form  
A + E

5

Bestell-Nr. Order no. Référence	HSK	THOD	BD1	OAL	TQX	EUR
A32.700	HSK 32	M10 × 1	6	26,0	5	12,00
A40.700	HSK 40	M12 × 1	8	29,5	10	12,00
A50.700	HSK 50	M16 × 1	10	33,0	15	14,00
A63.700	HSK 63	M18 × 1	12	36,5	20	11,00
A80.700	HSK 80	M20 × 1,5	14	40,0	25	15,00
A100.700	HSK 100	M24 × 1,5	16	44,0	30	14,00

- Hinweis:** Nach ISO 22402-1 (ehemals DIN 69895) für HSK-A und HSK-E Kegel-Hohlschäfte  
Axial abgedichtet mit zwei O-Ringen  
Dichtigkeit der Verschraubung getestet bis 80 bar  
Schützt vor Werkzeugbruch und erleichtert die Fehleranalyse
- Note:** According to ISO 22402-1 (formerly DIN 69895) for HSK-A and HSK-E hollow taper shanks  
Axial sealed with two O-rings  
Tightness of the screw connection tested up to 80 bar  
After mounting, the coolant tube can be moved only to a minimum degree according to DIN (±1°)
- Observation:** Selon ISO 22402-1 (anciennement DIN 69895) pour HSK-A et HSK-E Tiges creuses coniques  
Étanche axiale avec deux joints toriques  
étanchéité du raccord testée jusqu'à 80 bar  
Après le montage, la canule de lubrification peut être déplacée légèrement suivant DIN (±1°)

ISO 22402-1:2021-11

Fluid-Transfereinheiten für Werkzeugschnittstellen  
Teil 1: Transfereinheiten für Hohlschaftkegel nach ISO 12164

Medium-transfer units for tool interfaces  
Part 1: Transfer units for hollow taper shanks in accordance with the ISO 12164 series

Unités de transfert de fluide pour les interfaces d'outils  
Partie 1: Unités de transfert pour queues à cône creux-face conformes à la série ISO 12164



Coolant pipe / Coolant tubes for conventional cooling with filter  
Canules de lubrification pour le refroidissement conventionnel avec filtre



**Verwendung:**  
Zur zentralen Übergabe von Kühlmittel bei HSK-Werkzeugaufnahmen.

**Application:**  
For the coolant supply through the centre of HSK toolholders.

**Application:**  
Pour l'arrosage centrale de porte-outils HSK.

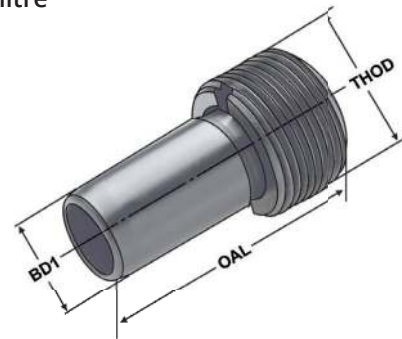

DIN 69895  
Form A + E

Bestell-Nr. Order no. Référence	HSK	THOD	BD1	OAL	TQX	EUR
A63.700.F.100	HSK 63	M18 × 1	12	36,5	20	49,00
A100.700.F.100	HSK 100	M24 × 1,5	16	44,0	30	54,00

5



**Hinweis:** Mit Filter für schmutzpartikelfreie Kühlung  
100µ Edelstahl-Gewebefilter  
Dichtigkeit der Verschraubung getestet bis 80 bar  
Die Kühlmittelübergabeeinheit ist nach dem Einbau, gemäß DIN, minimal beweglich (±1°)

**Note:** With filter for dirt particle-free cooling  
100µ stainless steel mesh filter  
Tightness of the screw connection tested up to 80 bar  
After mounting, the coolant tube can be moved only to a minimum degree according to DIN (±1°)

**Observation:** Avec filtre pour un refroidissement sans particules de saleté  
Filtre en tissu d'acier inoxydable 100µ  
étanchéité du raccord testée jusqu'à 80 bar  
Après le montage, la canule de lubrification peut être déplacée légèrement suivant DIN (±1°)





**Werkzeugaufnahmen  
DIN 69893-5 - HSK-E**

***Toolholders  
DIN 69893-5 - HSK-E***

**Porte-outils  
DIN 69893-5 - HSK-E**

**DISCOUNT P&GE 20%**  
**DIN 6350-5 HSK-E**



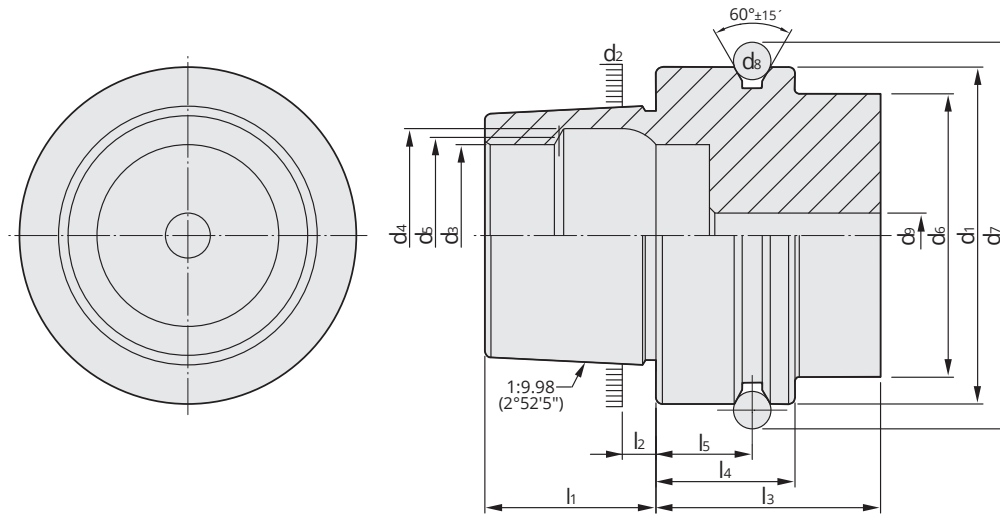

5

HSK	d <sub>1</sub> h10	d <sub>2</sub>	d <sub>3</sub> H10	d <sub>4</sub> H11	d <sub>5</sub>	d <sub>6</sub> max	d <sub>7</sub> 0 -0,1	d <sub>8</sub>	d <sub>9</sub> max	l <sub>1</sub> 0 -0,2	l <sub>2</sub>	l <sub>3</sub>	l <sub>4</sub> 0 -0,1	l <sub>5</sub> ±0,1
25	25	19,006	14	16,4	15	20	28,5	3	3	13	2,5	20	10	4,5
32	32	24,007	17	20,5	19	26	37	4	4,2	16	3,2	35	20	16
40	40	30,007	21	25,5	23	34	45	4	5	20	4	35	20	16
50	50	38,009	26	32	29	42	59,3	7	6,8	25	5	42	26	18
63	63	48,010	34	40	37	53	72,3	7	8,4	32	6,3	42	26	18
80	80	60,012	42	50	46	68	88,8	7	10,2	40	8	42	26	18
100	100	75,013	53	63	58	88	109,75	7	12	50	10	45	29	20
125	125	95,016	67	80	73	111	134,75	7	14	63	12,5	45	29	20

**Vorgewuchtet**  
Pre-balanced  
Pré-équilibré

**G 6,3 15.000 min<sup>-1</sup>**

**G 2,5 Feinwuchten gegen Aufpreis**

G 2.5 Fine balancing at extra charge

G 2,5 Equilibrage fin contre un supplément

**Werkstoff:** Legierter Einsatzstahl mit einer Zugfestigkeit im Kern von min. 950 N / mm<sup>2</sup>. Einsatzgehärtet HRC 60 ± 2 (HV 700 ± 50), Härtetiefe 0,8 mm ± 0,2 mm, brüniert und präzisionsgeschliffen.

**Genauigkeit:** Kegelwinkel – Toleranzqualität < AT 3 nach DIN 7187.

**Material:** Alloyed case-hardened steel, tensile core strength of min. 950 N / mm<sup>2</sup>. Case hardened HRC 60 ± 2 (HV 700 ± 50), hardening depth 0.8 mm ± 0.2 mm, black-finished and precisely grinded.

**Accuracy:** Quality of taper < AT 3 according to DIN 7187.

**Matière:** Acier de cémentation allié. Résistance à la traction dans le noyau de min 950 N / mm<sup>2</sup>. Cémentation à HRC 60 ± 2 (HV 700 ± 50), profondeur de cémentation 0,8 mm ± 0,2 mm, bruni et rectifié précisément.

**Précision:** Qualité du cône < AT 3 suivant DIN 7187.

**Normative Verweise:**

ISO 12164-1:2023-10  
Hohlkegelschnittstelle mit Plananlage -  
Teil 1: Schäfte der Typen A, AB, C, CB und EB

**Normative references:**

ISO 12164-1:2023-10  
Hollow taper interface with flange contact surface -  
Part 1: Shanks of types A, AB, C, CB and EB

**Références normatives:**

ISO 12164-1:2023-10  
Interfaces à cône creux-face  
Partie 2: Nez de broches de type A, C et E pour queues  
à cône creux-face de type A, AB, C, CB et EB

DIN 69893-5:2024-05  
Kegel-Hohlschäfte mit Plananlage -  
Teil 5: Kegel-Hohlschäfte Form E - Maße und Ausführung

DIN 69893-5:2024-05  
Hollow taper shanks with flat contact surface -  
Part 5: Hollow taper shanks type E - Dimensions and design

DIN 69893-5:2024-05  
Queues creuses coniques à surface de contact plane:  
Partie 1: Queues creuses coniques type E;  
Dimensions and conception



*Index*  
Sommaire

5.57



5.58



5.59



5.60



5.61



5.62







Collet chucks for collets ISO 15488 (DIN 6499) system ER  
Mandrins à pinces pour pinces ISO 15488 (DIN 6499) système ER



**Verwendung:**  
Zur Aufnahme von Werkzeugen mit Zylinderschaft in Spannzangen.

**Application:**  
For mounting straight-shank tools in collets.

**Application:**  
Destiné à recevoir les outils avec les queues de forme cylindrique dans les pinces de serrage.

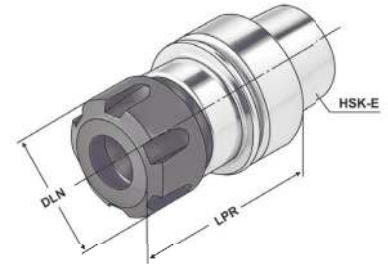

ISO 12164	Form E	$\leq 3\mu\text{m}$	G2,5 25.000 min <sup>-1</sup>	ISO 15488
-----------	--------	---------------------	-------------------------------	-----------

**i**  
13.04

5

Bestell-Nr. Order no. Référence	HSK	DCONWS Spannbereich Capacity   Capacité	Typ	LPR	DLN	DRVS	THID	EUR
E40.02.10	HSK-E 40	1 - 10	426E   ER 16	65	32	24	M10 x 1,5	119,00
E40.02.13	HSK-E 40	1 - 13	428E   ER 20	60	35	30	M12 x 1,75	119,00
E40.02.16	HSK-E 40	2 - 16	430E   ER 25	75	42	32	M16 x 2,0	120,00
E40.02.20	HSK-E 40	2 - 20	470E   ER 32	100	50	48	M16 x 2,0	123,00
E63.02.20	HSK-E 63	2 - 20	470E   ER 32	90	50	46	M16 x 2,0	120,00
E63.02.26	HSK-E 63	3 - 26	472E   ER 40	120	63	46	M16 x 2,0	130,00

**Lieferumfang:** Mit gewuchteter Spannmutter  
**Delivery:** With balanced clamping nut  
**Livraison:** Avec écrou de serrage équilibré



für Spannzangen ISO 15488 (DIN 6499)

**Precision collet chuck ER for collets ISO 15488 (DIN 6499) ER-system**  
**Mandrin à pinces ER de précision pour pinces ISO 15488 (DIN 6499) système ER**



**Verwendung:**  
 Zur Aufnahme von Werkzeugen mit Zylinderschaft in 3 µm-Spannzangen.

**Application:**  
 For mounting straight-shank tools in 3 µm-collets.

**Utilisation:**  
 Pour la fixation d'outils à queue cylindrique dans les pinces de serrage de 3 µm.

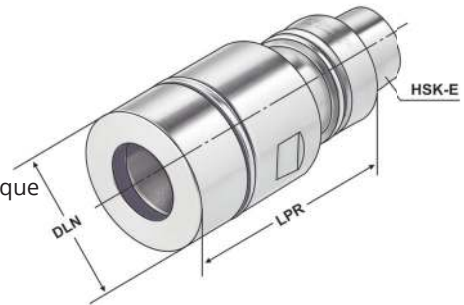

ISO 12164 Form E  $\leq 3\mu\text{m}$  G2.5 25.000 min<sup>-1</sup> ISO 15488

i 13.04

Bestell-Nr. Order no. Référence	HSK	DCONWS Spannbereich Capacity   Capacité	Typ	LPR	DLN	DRVS	THID	EUR
E40.P2.20.070	HSK-E 40	2 – 20	470E   ER 32	70	50	30	M16 x 2,0	125,00
E50.P2.20.070	HSK-E 50	2 – 20	470E   ER 32	70	50	38	M16 x 2,0	130,00

5

**Vorteile:**

- Exzellente Rundlaufgenauigkeit im System (Futter + Spannzange + Spannmutter)
- Extreme Haltekräfte (erhöht die Haltekraft um mindestens 60 % im Vergleich zu Standard ER-Futter)
- Glatte Spannmutter ohne Nuten für Hochgeschwindigkeitsbearbeitung

**Advantages:**

- Excellent concentricity in the system (chuck + collet + clamping nut)
- Extremely strong holding force (increases the holding power by at least 60% compared to standard ER chuck)
- Plain clamping nut without grooves for high speed machining

**Avantages:**

- Excellente concentricité du système (mandrin + pince de serrage + écrou de serrage)
- La force de rétention est extrêmement forte (augmente la force de rétention d'au moins 60 % par rapport aux mandrins ER standard)
- Ecrou de serrage lisse sans rainures pour l'usinage à grande vitesse

**Hinweis:**

Nur das Nennmaß DCONWS kann gespannt werden.

**Note:**

Only nominal size DCONWS can be clamped.

**Observation:**

Seulement la dimension nominale DCONWS peut être serrée.

**Lieferumfang:**

Inklusive Präzisions-Spannmutter

**Delivery:**

With precision clamping nut

**Livraison:**

Avec écrou de serrage de précision





Collet chucks for collets | KPS-system  
Mandrins à pinces pour pinces | Système KPS



**Verwendung:**  
Zur Aufnahme von Werkzeugen mit Zylinder-  
schaft in Spannzangen.  
Für Anwendungen im HSC-Bereich und für  
hochpräzise Bearbeitungsergebnisse.

**Application:**  
For mounting straight-shank tools in collets.  
To use for high speed cutting and high precision  
milling.

**Utilisation:**  
Pour la fixation d'outils à queue cylindrique  
dans les pinces de serrage. Pour l'UGV (Usi-  
nage à Grande Vitesse) et pour des résultats  
d'usinage de haute précision.

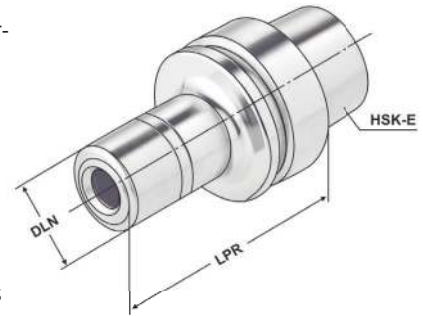

ISO 12164	Form E	$\leq 3\mu\text{m}$	G2,5 30.000 min <sup>-1</sup>	KPS
--------------	-----------	---------------------	-------------------------------------	-----

13.04

5

Bestell-Nr. Order no. Référence	HSK	DCONWS Spannbereich Capacity   Capacité	Typ	LPR	DLN	DRVS	THID	EUR
E40.03.10	HSK-E 40	1 - 10	490E   KPS 10	75	27,5	26	M12 x 1,75	120,00
E40.03.16	HSK-E 40	4 - 16	496E   KPS 16	75	40,0	38	M18 x 1,50	125,00
E63.03.10	HSK-E 63	1 - 10	490E   KPS 10	105	27,5	26	M12 x 1,75	130,00
E63.03.16	HSK-E 63	4 - 16	496E   KPS 16	120	40,0	38	M18 x 1,50	135,00

**Lieferumfang:** Mit gewuchteter Spannmutter  
**Delivery:** With balanced clamping nut  
**Livraison:** Avec écrou de serrage équilibré



CNC-Drill chucks for clockwise and counter clockwise rotation  
Mandrins de perçage CNC pour rotation gauche-droite



**Verwendung:**  
Zur Aufnahme von Werkzeugen mit  
Zylinderschaft.  
**Application:**  
For mounting tools with straight shanks.  
**Application:**  
Pour le serrage d'outils avec queue  
cylindrique.

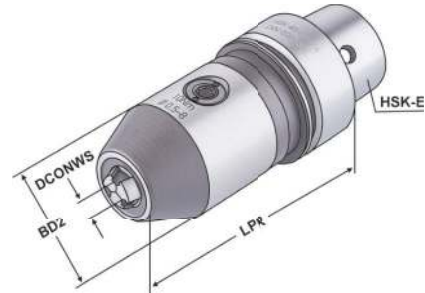

Bestell-Nr. Order no. Référence	HSK	DCONWS Spannbereich Capacity   Capacité	LPR	BD	DRVS	EUR
E40.15.08	HSK-E 40	0,5 – 8	85	36	4	529,00

5

- Hinweis:** Hohe Präzision und Rundlaufgenauigkeit von  $\leq 0,03$  mm. Kein selbständiges Lösen der Spannung während der Bearbeitung bei Links- oder Rechtslauf, sowie bei Spindelstop. Spannen und Lösen mit Sechskantschlüssel.
- Note:** High precision and accurate concentricity of  $\leq 0.03$  mm. No automatic slackening of the clamping force while machining with either clockwise or counter clockwise rotation or on spindle stop. Clamping and releasing effected by means of an Allen wrench.
- Observation:** Précision élevée et exactitude de circularité de  $\leq 0,03$  mm. Pas de desserrage intempestif en cours d'usinage lors de la rotation la gauche ou la droite, de même qu'en cas d'arrêt de la broche. Serrage et desserrage en utilisant un clé sur à fourche.

**Lieferumfang:** Ohne Spannschlüssel  
**Delivery:** Without wrench  
**Livraison:** Sans clé de serrage





**Verwendung:**  
Zur Aufnahme von Werkzeugen mit Zylinderschaft nach DIN 1835 Form A+B+E und DIN 6535 Form HA+HB+HE (größer Ø 20 mm nur mit Reduzierung).

**Application:**  
For mounting straight-shank tools acc. DIN 1835 form A+B+E and DIN 6535 form HA+HB+HE (larger than dia. 20 mm only with reduction sleeve).

**Application:**  
Pour le serrage d'outils avec queue cylindrique suivant DIN 1835 forme A+B+E et DIN 6535 forme HA+HB+HE.

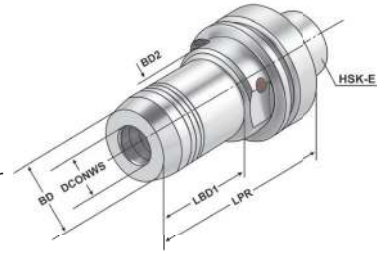

5

Bestell-Nr. Order no. Référence	HSK	DCONWS	LPR	BD	BD2	LSCX	ADJRGA	LBD1	DRVS	THID	EUR
E40.H12	HSK-E 40	12	90	32	34	47	10	47	5	M8x1	369,00
E40.H20	HSK-E 40	20	100	42	50	52	10	-	5	M12x1	369,00
E63.H12	HSK-E 63	12	90	32	50	47	10	44,5	5	M10x1	369,00
E63.H20	HSK-E 63	20	100	42	50	52	10	58	5	M12x1	369,00

LSCX = Einspannlänge, max.      ADJRGA = Verstellweg, max.  
LSCX = Clamping depth, max.    ADJRGA = Length adjustment range, max.  
LSCX = Profondeur d'insertion, max.    ADJRGA = Course de réglage, max.

Lieferumfang: Ohne Spannschlüssel  
Delivery: Without wrench  
Livraison: Sans clé de serrage

**Spannkraft-Prüfgerät für Hydrodehnspannfutter - Seite 12.61**

Clamping force proofing instrument for hydraulic chucks - page 12.61

Appareil de contrôle des forces de serrage pour mandrin expansibles hydrauliques - page 12.61



zum Spannen von HM und HSS Werkzeugen

*Shrink chucks 4,5° for mounting of solid carbide and HSS-tool shanks*

*Mandrins de frettage 4,5° pour le serrage de queues d'outils carbures de type HM et HSS*



**Verwendung:**  
Zur Aufnahme von Werkzeugen mit Zylinderschaft.

**Application:**  
*For mounting straight-shank tools.*

**Application:**  
Pour le serrage d'outils avec queue cylindrique.

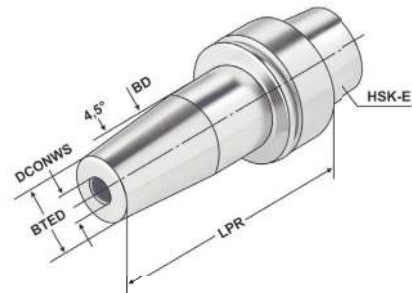

ISO 12164    Form E     $\leq 3\mu\text{m}$     G2.5 25.000 min<sup>-1</sup>    h6

Bestell-Nr. Order no. Référence	HSK	DCONWS	TDCON	LPR	BTED	BD	LSCN	LSCX	ADJRGA	THID	EUR
E40.70.03	HSK-E 40	3	h4	80	9	18	10	18	-	-	132,00
E40.70.04	HSK-E 40	4	h4	80	10	22	10	20	5	-	132,00
E40.70.05	HSK-E 40	5	h4	80	16	22	10	20	5	-	132,00
E40.70.06	HSK-E 40	6	h6	80	21	27	26	36	10	M5	119,00
E40.70.08	HSK-E 40	8	h6	80	21	27	26	36	10	M6	119,00
E40.70.10	HSK-E 40	10	h6	80	24	32	32	42	10	M8x1	119,00
E40.70.12	HSK-E 40	12	h6	90	24	32	37	47	10	M8x1	119,00
E40.70.14	HSK-E 40	14	h6	90	27	34	37	47	10	M10x1	119,00
E40.70.16	HSK-E 40	16	h6	90	27	34	40	50	10	M12x1	119,00

5

LSCX = Einspannlänge, max.    ADJRGA = Verstellweg, max.  
 LSCX = Clamping depth, max.    ADJRGA = Length adjustment range, max.  
 LSCX = Profondeur d'insertion, max.    ADJRGA = Course de réglage, max.

**Hinweis:** Aufnahme für Induktiv-, Kontakt- und Heißluftschumpfgeräte geeignet.  
 Schafttoleranz bei Ø 3, 4 und 5 mm = h<sub>4</sub>, bei Ø 6 - Ø 32 mm = h<sub>6</sub>

**Note:** *Toolholders suitable for induction-, contact- and hot air shrink units.  
 Ø 3, 4, 5 with h<sub>4</sub>-tolerance and Ø 6 - Ø 32 with h<sub>6</sub>-tolerance*

**Observation:** Porte-outils convenables pour machines à fretter par induction, par contact, ou par air chaud.  
 Ø 3, 4, 5 avec h<sub>4</sub>-tolerance et Ø 6 - Ø 32 avec h<sub>6</sub>-tolerance





**Werkzeugaufnahmen  
DIN 69893-6 - HSK-F**

***Toolholders  
DIN 69893-6 - HSK-F***

**Porte-outils  
DIN 69893-6 - HSK-F**

**DISCOUNT**  
**P&GE 20%**  
**DIN 69893-6 HSK-F**



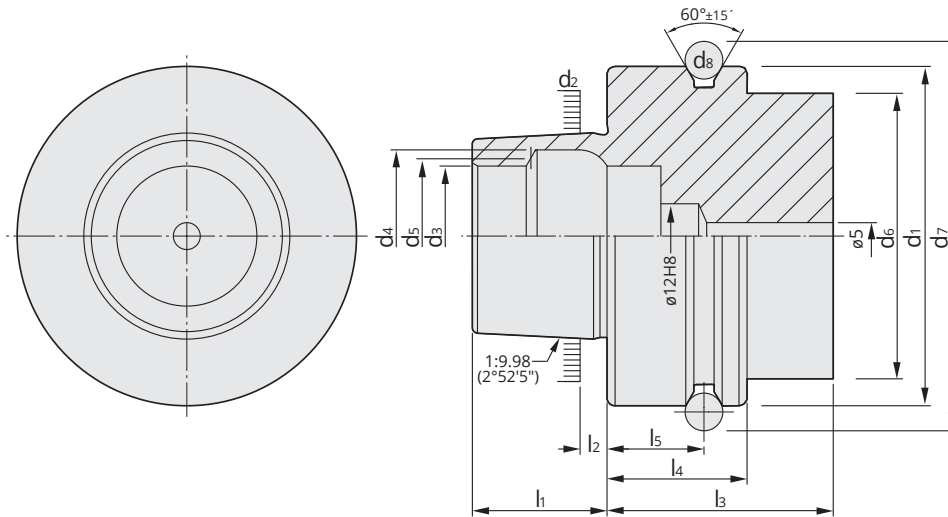

**5**

HSK	d <sub>1</sub> h10	d <sub>2</sub>	d <sub>3</sub> H10	d <sub>4</sub> H11	d <sub>5</sub>	d <sub>6</sub> max	d <sub>7</sub> 0 -0,1	d <sub>8</sub>	l <sub>1</sub> 0 -0,2	l <sub>2</sub>	l <sub>3</sub> min	l <sub>4</sub> 0 -0,1	l <sub>5</sub> ±0,1
50	50	30,007	21	25,5	23	42	59,3	7	20	4	42	26	18
63	63	38,009	26	32	29	53	72,3	7	25	5	42	26	18

**Vorgewuchtet** **G 6,3 15.000 min<sup>-1</sup>**  
*Pre-balanced*  
 Pré-équilibré

**G 2,5 Feinwuchten gegen Aufpreis**  
*G 2.5 Fine balancing at extra charge*  
 G 2,5 Equilibrage fin contre un supplément

**Werkstoff:** Legierter Einsatzstahl mit einer Zugfestigkeit im Kern von min. 950 N / mm<sup>2</sup>.  
 Einsatzgehärtet HRC 60 ± 2 (HV 700 ± 50), Härtetiefe 0,8 mm ± 0,2 mm

**Genauigkeit:** Kegelwinkel – Toleranzqualität < AT 3 nach DIN 7187.

**Material:** *Alloyed case-hardened steel, tensile core strength of min. 950 N / mm<sup>2</sup>.  
 Case hardened HRC 60 ± 2 (HV 700 ± 50), hardening depth 0.8 mm ± 0.2 mm*

**Accuracy:** *Quality of taper < AT 3 according to DIN 7187.*

**Matière:** Acier de cémentation allié. Résistance à la traction dans le noyau de min 950 N / mm<sup>2</sup>.  
 Cémentation à HRC 60 ± 2 (HV 700 ± 50), profondeur de cémentation 0,8 mm ± 0,2 mm

**Précision:** Qualité du cône < AT 3 suivant DIN 7187.

**Normative Verweise:**

DIN 69893-1:2011  
 Kegel-Hohlschäfte mit Plananlage besteht aus:  
 - Teil 6: Kegel-Hohlschäfte Form F  
 Maße und Ausführung

**Normative references:**

DIN 69893-1:2011  
 Hollow taper shanks with flange contact surface:  
 - Part 1: Part 6: Hollow taper shank type F;  
 Dimensions and design

**Références normatives:**

DIN 69893-1:2011  
 Queues creuses coniques à surface de contact plane:  
 - Partie 1: Queues creuses coniques type A et type C;  
 Dimensions et conception



Index  
Sommaire

5.67	5.68	5.69	5.70
5.71	5.72	5.73	5.74
5.75	5.76	5.77	5.78
5.79	5.81		



Collet chucks for collets ISO 15488 (DIN 6499) système ER  
Mandrins à pinces pour pinces ISO 15488 (DIN 6499) système ER



**Verwendung:**  
Zur Aufnahme von Werkzeugen mit Zylinderschaft in Spannzangen.

**Application:**  
For mounting straight-shank tools in collets.

**Application:**  
Destiné à recevoir les outils avec les queues de forme cylindrique dans les pinces de serrage.

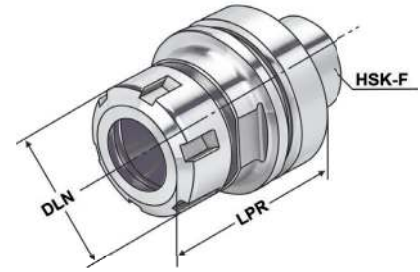

ISO 12164	Form F	$\leq 3\mu\text{m}$	G2,5 25.000 min <sup>-1</sup>	ISO 15488
-----------	--------	---------------------	-------------------------------	-----------

i 13.04

5

Bestell-Nr. Order no. Référence	HSK	DCONWS Spannbereich Capacity   Capacité	Typ	LPR	DLN	THID	DRVS	EUR
F63.02.10	HSK-F 63	1 – 10	426E   ER 16	60	32	-	28	98,00
F63.02.16	HSK-F 63	2 – 16	430E   ER 25	70	42	-	38	98,00
F63.02.20	HSK-F 63	2 – 20	470E   ER 32	70	50	-	46	102,00
F63.02.26	HSK-F 63	3 – 26	472E   ER 40	75	63	-	46	110,00
F63.02.10.1	HSK-F 63	1 – 10	426E   ER 16	100	32	M10 x 1,5	28	100,00
F63.02.16.1	HSK-F 63	2 – 16	430E   ER 25	100	42	M16 x 2,0	38	100,00
F63.02.20.1	HSK-F 63	2 – 20	470E   ER 32	100	50	M16 x 2,0	46	104,00
F63.02.26.1	HSK-F 63	3 – 26	472E   ER 40	100	63	M16 x 2,0	46	112,00
F63.02.10.2	HSK-F 63	1 – 10	426E   ER 16	160	32	M10 x 1,5	28	147,00
F63.02.16.2	HSK-F 63	2 – 16	430E   ER 25	160	42	M16 x 2,0	38	147,00
F63.02.20.2	HSK-F 63	2 – 20	470E   ER 32	160	50	M16 x 2,0	46	152,00
F63.02.26.2	HSK-F 63	3 – 26	472E   ER 40	160	63	M16 x 2,0	46	163,00

**Lieferumfang:** Mit gewuchteter Spannmutter  
**Delivery:** With balanced clamping nut  
**Livraison:** Avec écrou de serrage équilibré

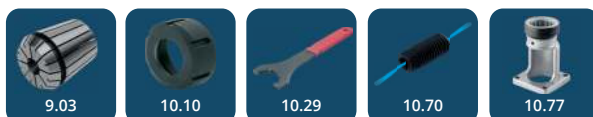

## System ER - Mini

Collet chucks for collets ISO 15488 (DIN 6499) ER-system - Mini

Mandrin de serrage pour pinces ISO 15488 (DIN 6499) système ER - Mini



**Verwendung:**  
Zur Aufnahme von Werkzeugen mit  
Zylinderschaft in Spannzangen.

**Application:**  
For mounting straight-shank tools in  
collets.

**Utilisation:**  
Pour la fixation d'outils à queue cylindrique dans les pinces de serrage.

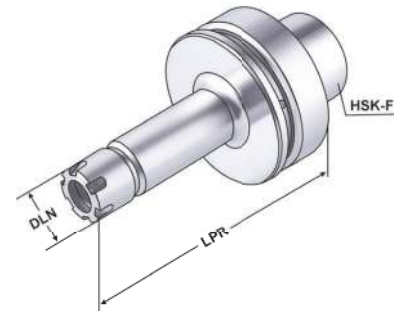

Bestell-Nr. Order no. Référence	HSK	DCONWS Spannbereich Capacity   Capacité	Typ	LPR	DLN	THID	DRVS	EUR
F63.02.07.10.1	HSK-F 63	1 – 10	426E   ER 16	100	22	7/16" 20 UNF	18	151,00
F63.02.07.10.130	HSK-F 63	1 – 10	426E   ER 16	130	22	7/16" 20 UNF	18	182,00
F63.02.07.10.2	HSK-F 63	1 – 10	426E   ER 16	160	22	7/16" 20 UNF	18	223,00

5

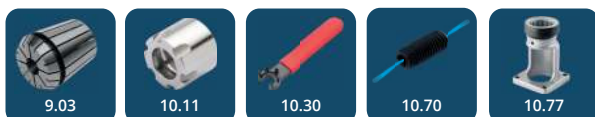

**Precision collet chuck ER for collets ISO 15488 (DIN 6499) ER-system**

**Mandrin à pinces ER de précision pour pinces ISO 15488 (DIN 6499) système ER**



**Verwendung:**

Zur Aufnahme von Werkzeugen mit Zylinderschaft in 3 µm-Spannzangen.

**Application:**

For mounting straight-shank tools in 3 µm-collets.

**Application:**

Pour le serrage d'outils avec queue cylindrique dans des pinces de serrage 3 µm.



ISO 12164	Form F	≤ 3µm	G2,5 25.000 min <sup>-1</sup>	ISO 15488	i 13.04
-----------	--------	-------	-------------------------------	-----------	---------

5

Bestell-Nr. Order no. Référence	HSK	DCONWS Spannbereich Capacity   Capacité	Typ	LPR	LB	DLN	DRVS	THID	EUR
F63.P2.20.100	HSK-F 63	2 - 20	470E   ER 32	100	71	50	48	M16 x 2,0	129,00

**Vorteile:**

- Exzellente Rundlaufgenauigkeit im System (Futter + Spannzange + Spannmutter)
- Extreme Haltekräfte (erhöht die Haltekraft um mindestens 60 % im Vergleich zu Standard ER-Futter)
- Glatte Spannmutter ohne Nuten für Hochgeschwindigkeitsbearbeitung

**Advantages:**

- Excellent concentricity in the system (chuck + collet + clamping nut)
- Extremely strong holding force (increases the holding power by at least 60% compared to standard ER chuck)
- Plain clamping nut without grooves for high speed machining

**Avantages:**

- Excellente précision de concentricité dans le système (mandrin + pince de serrage + écrou de serrage)
- La force de maintien extrême (augmente la force de maintien d'au moins à 60% par rapport aux mandrins standards ER)
- Ecrou de serrage lisse sans rainures pour l'usinage à haute vitesse

**Hinweis:**

Nur das Nennmaß DCONWS kann gespannt werden.

**Note:**

Only nominal size DCONWS can be clamped.

**Observation:**

Seulement la dimension nominale DCONWS peut être serrée.

**Lieferumfang:**

Inklusive Präzisions-Spannmutter

**Delivery:**

With precision clamping nut

**Livraison:**

Avec écrou de serrage de précision

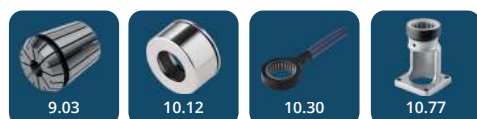

Collet chucks for collets | KPS-system  
Mandrins à pinces pour pinces | Système KPS



**Verwendung:**  
Zur Aufnahme von Werkzeugen mit Zylinder-  
schaft in Spannzangen.  
Für Anwendungen im HSC-Bereich und für  
hochpräzise Bearbeitungsergebnisse.

**Application:**  
For mounting straight-shank tools in collets.  
To use for high speed cutting and high precision  
milling.

**Utilisation:**  
Pour la fixation d'outils à queue cylindrique  
dans les pinces de serrage. Pour l'UGV (Usi-  
nage à Grande Vitesse) et pour des résultats  
d'usinage de haute précision.

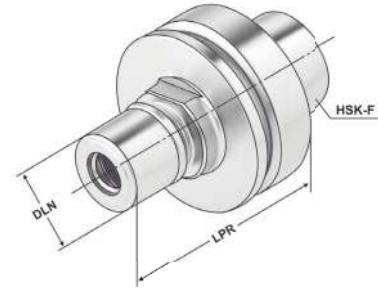

Bestell-Nr. Order no. Référence	HSK	DCONWS Spannbereich Capacity   Capacité	Typ	LPR	DLN	DRVS	THID	EUR
F63.03.10	HSK-F 63	1 – 10	490EK   KPS 10	90	27,5	26	M12 x 1,75	130,00
F63.03.16	HSK-F 63	4 – 16	496EK   KPS 16	90	40,0	38	M12 x 1,75	135,00

5

**Lieferumfang:** Mit gewuchteter Spannmutter  
**Delivery:** With balanced clamping nut  
**Livraison:** Avec écrou de serrage équilibré

## Gewuchtete Ausführung

Balanced type  
Type équilibré



Bestell-Nr. Order no. Référence	Ausführung Version Exécution
---------------------------------------	------------------------------------

### Wuchten auf G 2,5 von vorgewuchteten Kemmler-Werkzeugen

Balancing at G 2,5 of pre-balanced Kemmler-tools  
Équilibrage G 2,5 d'outils Kemmler pré-équilibrés

W25 **Ohne Wuchtprotokoll**  
Without balancing report  
Sans protocole d'équilibrage

W25.2 **Mit Wuchtprotokoll**  
With balancing report  
Avec protocole d'équilibrage

Wuchten von nicht vorgewuchteten Werkzeugen  
Balancing of unbalanced tools  
Équilibrage d'outils non-équilibrés

W25.1 **Ohne Wuchtprotokoll**  
Without balancing report  
Sans protocole d'équilibrage





Collet chucks for collets ISO 10897 (DIN 6388) système OZ  
Mandrins à pinces pour pinces ISO 10897 (DIN 6388) système OZ



**Verwendung:**  
Zur Aufnahme von Werkzeugen mit Zylinderschaft in Spannzangen.

**Application:**  
For mounting straight-shank tools in collets.

**Application:**  
Destiné à recevoir les outils avec les queues de forme cylindrique dans les pinces de serrage.

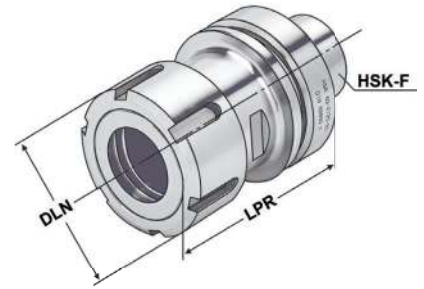

ISO 12164	Form F	$\leq 3\mu\text{m}$	G2,5 25.000 min <sup>-1</sup>	ISO 10897
-----------	--------	---------------------	-------------------------------	-----------

**i**  
13.04

5

Bestell-Nr. Order no. Référence	HSK	DCONWS Spannbereich Capacity   Capacité	Typ	LPR	DLN	DRVS	EUR
F63.01.25	HSK-F 63	2 - 25	462E   OZ 25	85	60	44	115,00

**Lieferumfang:** Mit gewuchteter Spannmutter  
**Delivery:** With balanced clamping nut  
**Livraison:** Avec écrou de serrage équilibré



End mill holders DIN 6359 for end mills DIN 1835-B  
Porte-fraises DIN 6359 pour queues cylindriques DIN 1835-B

**Verwendung:**

Zum Spannen von zylindrischen Werkzeugschäften mit seitlicher Spannfläche nach DIN 1835 Form B (Weldon).

**Application:**

For mounting straight-shank tools with lateral flat according to DIN 1835 form B (Weldon).

**Application:**

Pour le serrage d'outils avec queue cylindrique et avec méplat de serrage latérale suivant DIN 1835 forme B (Weldon).

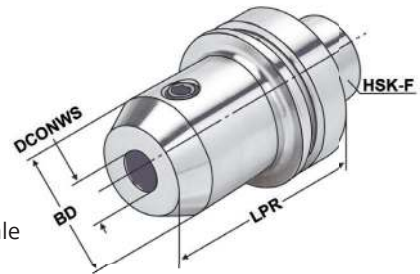

Bestell-Nr. Order no. Référence	HSK	DCONWS	TDCON	LPR	BD	EUR
F63.04.06	HSK-F 63	6	H4	65	25	104,00
F63.04.08	HSK-F 63	8	H4	65	28	104,00
F63.04.10	HSK-F 63	10	H4	65	35	104,00
F63.04.12	HSK-F 63	12	H4	80	42	104,00
F63.04.14	HSK-F 63	14	H4	80	44	104,00
F63.04.16	HSK-F 63	16	H4	80	48	104,00
F63.04.18	HSK-F 63	18	H4	80	48	104,00
F63.04.20	HSK-F 63	20	H4	80	52	104,00
F63.04.25	HSK-F 63	25	H4	110	65	122,00
F63.04.32	HSK-F 63	32	H4	110	72	130,00

5

**Hinweis:** Ab DCONWS = 25 mit zwei Spannschrauben  
**Note:** From DCONWS = 25 on two clamping screws  
**Observation:** A partir de DCONWS = 25 avec deux vis de serrage

**Lieferumfang:** Mit Spannschraube  
**Delivery:** With clamping screw  
**Livraison:** Avec vis de serrage





Shell mill holders DIN 6357 with enlarged contact face  
Porte-fraises à trou lisse DIN 6357 avec face de contact élargie



**Verwendung:**  
Zur Aufnahme von Messerköpfen und Fräsern mit Quernut.

**Application:**  
For mounting milling cutters with transversal groove.

**Application:**  
Destiné à recevoir les fraises et les fraises avec des rainures transversales.

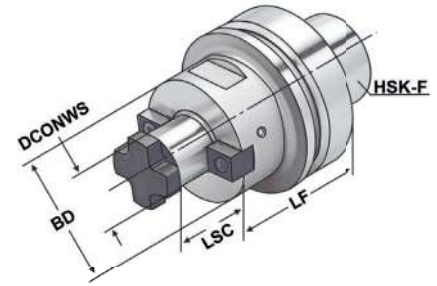

ISO 12164 Form F  $\leq 5\mu\text{m}$  G2,5 25.000 min<sup>-1</sup> DIN 6357 h6

i 13.04

5

Bestell-Nr. Order no. Référence	HSK	DCONWS	TCDCON	LF	LSC	BD	DRVS	EUR
F63.11.16	HSK-F 63	16	h6	50	17	40	34	122,00
F63.11.22	HSK-F 63	22	h6	50	19	48	44	122,00
F63.11.27	HSK-F 63	27	h6	60	21	60	54	122,00
F63.11.32	HSK-F 63	32	h6	60	24	78	74	126,00
F63.11.40	HSK-F 63	40	h6	100	27	89	84	187,00
F63.11.16.1	HSK-F 63	16	h6	100	17	40	34	147,00
F63.11.22.1	HSK-F 63	22	h6	100	19	48	44	147,00
F63.11.27.1	HSK-F 63	27	h6	100	21	60	54	147,00
F63.11.32.1	HSK-F 63	32	h6	100	24	78	74	153,00
F63.11.16.2	HSK-F 63	16	h6	160	17	40	34	221,00
F63.11.22.2	HSK-F 63	22	h6	160	19	48	44	221,00
F63.11.27.2	HSK-F 63	27	h6	160	21	60	54	221,00

**DCONWS = 40** Für große Planfräser mit vier zusätzlichen Gewindebohrungen nach DIN 2079.  
For large diameter face mill cutters with four additional threaded holes according to DIN 2079.  
Pour fraises à surfacer à grands diamètres avec 4 taraudages supplémentaires suivant DIN 2079.

**Lieferumfang:** Mit Mitnehmersteinen, Kreuzschraube und Zylinderkopfschraube nach DIN 912 für Fräser mit innerer Kühlmittelzufuhr.  
**Delivery:** With drivers, cross head retaining screw and cylinder head retaining screw for cutters with central coolant.  
**Livraison:** Avec tenon d entraînement, vis cruciforme et vis à têtes cylindrique suivant DIN 912 pour les fraises avec arrosage central.



CNC-Drill chucks for clockwise and counter clockwise rotation  
Mandrins de perçage CNC pour rotation gauche-droite



**Verwendung:**  
Zur Aufnahme von Werkzeugen mit  
Zylinderschaft.  
**Application:**  
For mounting tools with straight shanks.  
**Application:**  
Pour le serrage d'outils avec queue  
cylindrique.

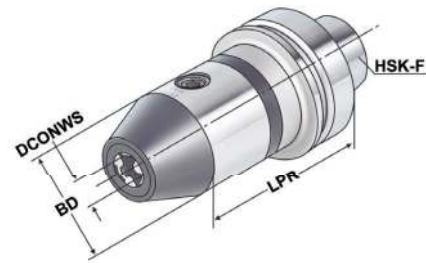

Bestell-Nr. Order no. Référence	HSK	DCONWS Spannbereich Capacity   Capacité	LPR	BD	DRVS	EUR
F63.15.13	HSK-F 63	1,0 - 13	110	50	6	292,00
F63.15.16	HSK-F 63	2,5 - 16	115	50	6	308,00

5

- Hinweis:** Hohe Präzision und Rundlaufgenauigkeit von  $\leq 0,03$  mm. Kein selbständiges Lösen der Spannung während der Bearbeitung bei Links- oder Rechtslauf, sowie bei Spindelstop. Spannen und Lösen mit Sechskantschlüssel.
- Note:** *High precision and accurate concentricity of  $\leq 0.03$  mm. No automatic slackening of the clamping force while machining with either clockwise or counter clockwise rotation or on spindle stop. Clamping and releasing effected by means of an Allen wrench.*
- Observation:** Précision élevée et exactitude de circularité de  $\leq 0,03$  mm. Pas de desserrage intempestif en cours d'usinage lors de la rotation la gauche ou la droite, de même qu'en cas d'arrêt de la broche. Serrage et desserrage en utilisant un clé sur à fourche.

**Lieferumfang:** Ohne Spannschlüssel  
**Delivery:** Without wrench  
**Livraison:** Sans clé de serrage

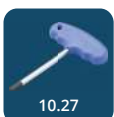

10.27



10.77



Quick change tapping chucks with length compensation on compression and expansion  
Mandrins de taraudage à changement rapide avec compensation longitudinale à la compression et traction



**Verwendung:**  
Zur Aufnahme von Schnellwechsel-Einsätzen für Gewindebohrer.

**Application:**  
For the chucking of quick change adaptors for taps.

**Application:**  
Pour le serrage d'adapteurs porte-tarauts à changement rapide.

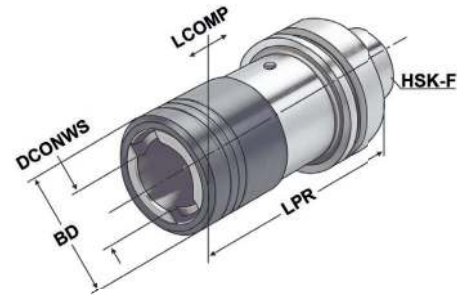

5

Bestell-Nr. Order no. Référence	HSK	Spannbereich Capacity Capacité	SZID	DCONWS	LPR	BD	LCOMP	EUR
F63.16.12	HSK-F 63	M3 - M14	1	19	102	36	7	350,00
F63.16.20	HSK-F 63	M5 - M22	2	31	140	53	12	380,00

**Hinweis:** Für Bearbeitungszentren ohne Synchronspindel.  
**Note:** For machining centres without synchronous spindle.  
**Observation:** Pour centres d'usinage sans broche synchrone.



Adaptor sleeves for MT with tang DIN 6383  
 Douilles de réduction pour CM à tenon DIN 6383



**Verwendung:**  
 Zur Aufnahme von Werkzeugen mit Morsekegelschaft und Austreiblappen nach DIN 228-1 Form B.

**Application:**  
 For mounting tools with Morse taper shank and tang according to DIN 228-1 form B.

**Application:**  
 Pour le serrage d'outils avec queue cône Morse et tenon suivant DIN 228-1 forme B.

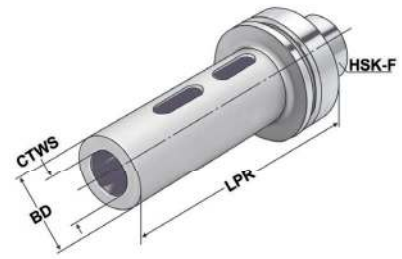

ISO 12164	Form F	$\leq 5\mu\text{m}$	G6.3 15.000 min <sup>-1</sup>	DIN 6383	AT5
--------------	-----------	---------------------	-------------------------------------	-------------	-----

Bestell-Nr. Order no. Référence	HSK	CTWS	TDCON	LPR	BD	EUR
F63.07.01	HSK-F 63	1	AT5	100	25	97,00
F63.07.02	HSK-F 63	2	AT5	120	32	97,00
F63.07.03	HSK-F 63	3	AT5	140	40	99,00
F63.07.04	HSK-F 63	4	AT5	160	48	101,00

5





Boring bar blanks  
Barres d'alésage



**Verwendung:**  
Zur Herstellung von Sonderwerkzeugen.  
**Application:**  
For the manufacturing of special tools.  
**Application:**  
Pour la fabrication d'outils spéciaux.

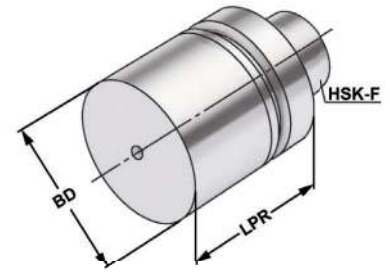

ISO 12164    Form F

5

Bestell-Nr. Order no. Référence	HSK	LPR	BD	EUR
F63.17.63	HSK-F 63	125	63	139,00
F63.17.63.1	HSK-F 63	250	63	170,00

**Ausführung:** Kegel und Bund gehärtet und geschliffen. Schaft weich zur weiteren Bearbeitung.  
**Version:** Cone and flange hardened and adjusted. Soft body for later processing.  
**Version:** Cône et collerette durcis et rectifiés. Corps doux pour un usinage ultérieur.

Test arbors  
Mandrins de contrôle



**Verwendung:**  
Zur Abnahme von Werkzeugmaschinen gemäß ISO-Empfehlung R230 oder zur Überprüfung der Werkzeugspindel.

**Application:**  
For the inspection of machine tools according to ISO recommendation R230 or for testing the tool spindle.

**Application:**  
Pour l'inspection de machine-outils suite à la recommandation ISO R230 ou pour la vérification de la broche.

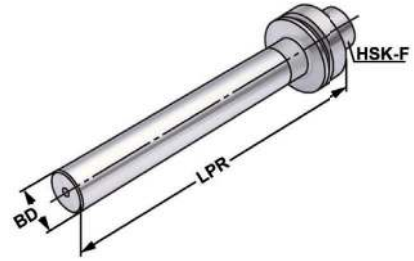

ISO 12164	Form F	 ≤ 3µm
--------------	-----------	-----------

Bestell-Nr. Order no. Référence	HSK	LPR	BD	Toleranz Tolerance Tolérance	max. Rundlaufabweichung max. concentricity deviation Faux-rond max.	EUR
F63.18.40	HSK-F 63	346	40	0,003	0,003	383,00

5

**Lieferumfang:** Auslieferung mit Prüfprotokoll  
**Delivery:** Delivery with test certificate  
**Livraison:** Livraison avec rapport d'essais

**Holzkasten für Kontrolldorne**  
Wooden box for test arbors  
Coffret en bois pour mandrins de contrôle



**Verwendung:**  
Zur Aufbewahrung von Kontrolldornen.

**Application:**  
For the storage of test arbors.

**Application:**  
Pour la conservation de mandrins de contrôle.



Bestell-Nr. Order no. Référence	Abmessung Size Dimension	für Kegelgrößen for cones pour cônes	EUR
701.18	460 × 130 × 115	SK 30 / 40 / 50	96,00



Shrink chucks 4,5° for mounting of solid carbide and HSS-tool shanks

Mandrins de frettage 4,5° pour le serrage de queues d'outils carbures de type HM et HSS

**Verwendung:**

Zur Aufnahme von Werkzeugen mit Zylinderschaft.

**Application:**

For mounting straight-shank tools.

**Application:**

Pour le serrage d'outils avec queue cylindrique.

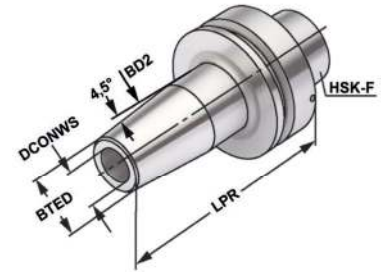

5

Bestell-Nr. Order no. Référence	HSK	DCONWS	TDCON	LPR	BTED	BD2	LSCN	LSCX	ADJRGA	THID	EUR
F63.70.03	HSK-F 63	3	h4	80	15	20	9	-	-	-	176,00
F63.70.04	HSK-F 63	4	h4	80	15	20	9	-	-	-	176,00
F63.70.05	HSK-F 63	5	h4	80	15	20	10	-	-	-	176,00
F63.70.06	HSK-F 63	6	h6	80	21	27	22	36	10	M5x0,8	153,00
F63.70.08	HSK-F 63	8	h6	80	21	27	26	36	10	M6x1	153,00
F63.70.10	HSK-F 63	10	h6	85	24	32	31	41	10	M8x1	153,00
F63.70.12	HSK-F 63	12	h6	90	24	32	36	46	10	M10x1	153,00
F63.70.14	HSK-F 63	14	h6	95	27	34	36	46	10	M10x1	153,00
F63.70.16	HSK-F 63	16	h6	95	27	34	39	49	10	M12x1	153,00
F63.70.18	HSK-F 63	18	h6	95	33	42	39	49	10	M12x1	153,00
F63.70.20	HSK-F 63	20	h6	100	33	42	41	51	10	M16x1	153,00
F63.70.25	HSK-F 63	25	h6	115	44	53	47	57	10	M16x1	153,00
F63.70.32	HSK-F 63	32	h6	125	44	53	51	61	10	M16x1	153,00
F63.70.03.1	HSK-F 63	3	h4	120	15	20	9	-	-	-	198,00
F63.70.04.1	HSK-F 63	4	h4	120	15	20	9	-	-	-	198,00
F63.70.05.1	HSK-F 63	5	h4	120	15	20	10	-	-	-	198,00
F63.70.06.1	HSK-F 63	6	h6	120	21	27	22	36	10	M5x0,8	176,00
F63.70.08.1	HSK-F 63	8	h6	120	21	27	26	36	10	M6x1	176,00
F63.70.10.1	HSK-F 63	10	h6	120	24	32	31	41	10	M8x1	176,00
F63.70.12.1	HSK-F 63	12	h6	120	24	32	36	46	10	M10x1	176,00
F63.70.14.1	HSK-F 63	14	h6	120	27	34	36	46	10	M10x1	176,00
F63.70.16.1	HSK-F 63	16	h6	120	27	34	39	49	10	M12x1	176,00
F63.70.18.1	HSK-F 63	18	h6	120	33	42	39	49	10	M12x1	176,00
F63.70.20.1	HSK-F 63	20	h6	120	33	42	41	51	10	M16x1	176,00

LSCX = Einspannlänge, max.

LSCX = Clamping depth, max.

LSCX = Profondeur d'insertion, max.

ADJRGA = Verstellweg, max.

ADJRGA = Length adjustment range, max.

ADJRGA = Course de réglage, max.

**Für Ø 3, 4 und 5 mm nur Hartmetallschäfte verwenden!**

For Ø 3, 4 and 5 mm only solid carbide tool shanks must be used!

Pour Ø 3, 4 et 5 mm il faut seulement utiliser de queues d'outils carbures de type HM!

**Hinweis:** Aufnahme für Induktiv-, Kontakt- und Heißluftschumpfergeräte geeignet.Schafftolleranz bei Ø 3, 4 und 5 mm = h<sub>4</sub>, bei Ø 6 - Ø 32 mm = h<sub>6</sub>**Note:** Toolholders suitable for induction-, contact- and hot air shrink units.Ø 3, 4, 5 with h<sub>4</sub>-tolerance and Ø 6 - Ø 32 with h<sub>6</sub>-tolerance**Observation:** Porte-outils convenables pour machines à fretter par induction, par contact, ou par air chaud.Ø 3, 4, 5 avec h<sub>4</sub>-tolerance et Ø 6 - Ø 32 avec h<sub>6</sub>-tolerance

zum Spannen von HM und HSS Werkzeugen

Shrink chucks 4,5° for mounting of solid carbide and HSS-tool shanks

Mandrins de frettage 4,5° pour le serrage de queues d'outils carbures de type HM et HSS



**Verwendung:**  
Zur Aufnahme von Werkzeugen mit Zylinderschaft.

**Application:**  
For mounting straight-shank tools.

**Application:**  
Pour le serrage d'outils avec queue cylindrique.

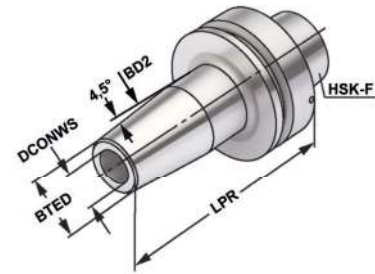

ISO 12164    Form F    ≤ 3µm    G2.5 25.000 min<sup>-1</sup>    h6

Bestell-Nr. Order no. Référence	HSK	DCONWS	TDCON	LPR	BTED	BD2	LSCN	LSCX	ADJRG	THID	EUR
F63.70.06.2	HSK-F 63	6	h6	160	21	27	22	36	10	M5x0,8	303,00
F63.70.08.2	HSK-F 63	8	h6	160	21	27	26	36	10	M6x1	303,00
F63.70.10.2	HSK-F 63	10	h6	160	24	32	31	41	10	M8x1	303,00
F63.70.12.2	HSK-F 63	12	h6	160	24	32	36	46	10	M10x1	303,00
F63.70.14.2	HSK-F 63	14	h6	160	27	34	36	46	10	M10x1	303,00
F63.70.16.2	HSK-F 63	16	h6	160	27	34	39	49	10	M12x1	303,00
F63.70.18.2	HSK-F 63	18	h6	160	33	42	39	49	10	M12x1	303,00
F63.70.20.2	HSK-F 63	20	h6	160	33	42	41	51	10	M16x1	303,00

5

LSCX = Einspannlänge, max.    ADJRG = Verstellweg, max.  
 LSCX = Clamping depth, max.    ADJRG = Length adjustment range, max.  
 LSCX = Profondeur d'insertion, max.    ADJRG = Course de réglage, max.

**Für Ø 3, 4 und 5 mm nur Hartmetallschäfte verwenden!**  
 For Ø 3, 4 and 5 mm only solid carbide tool shanks must be used!  
 Pour Ø 3, 4 et 5 mm il faut seulement utiliser de queues d'outils carbures de type HM!

- Hinweis:** Aufnahme für Induktiv-, Kontakt- und Heißluftschumpfgeräte geeignet.  
 Schafttoleranz bei Ø 3, 4 und 5 mm = h<sub>4</sub>, bei Ø 6 - Ø 32 mm = h<sub>6</sub>
- Note:** Toolholders suitable for induction-, contact- and hot air shrink units.  
 Ø 3, 4, 5 with h<sub>4</sub>-tolerance and Ø 6 - Ø 32 with h<sub>6</sub>-tolerance
- Observation:** Porte-outils convenables pour machines à fretter par induction, par contact, ou par air chaud.  
 Ø 3, 4, 5 avec h<sub>4</sub>-tolerance et Ø 6 - Ø 32 avec h<sub>6</sub>-tolerance







**Verwendung:**  
Zur Aufnahme von Werkzeugen mit Zylinderschaft nach DIN 1835 Form A+B+E und DIN 6535 Form HA+HB+HE (größer Ø 20 mm nur mit Reduzierung).

**Application:**  
For mounting straight-shank tools acc. DIN 1835 form A+B+E and DIN 6535 form HA+HB+HE (larger).

**Application:**  
Pour le serrage d'outils avec queue cylindrique suivant DIN 1835 forme A+B+E et DIN 6535 forme HA+HB+HE (à partir de dia. 20 mm seulement avec réduction).

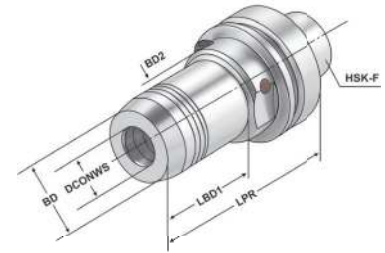

5

Bestell-Nr. Order no. Référence	HSK	DCONWS	LPR	BD	BD2	LSCX	ADJRGA	LBD1	DRVS	THID	EUR
F63.H06	HSK-F 63	6	100	26	50	37	10	45	5	M6x1	319,00
F63.H08	HSK-F 63	8	100	28	50	37	10	44	5	M6x1	319,00
F63.H10	HSK-F 63	10	100	30	50	42	10	46	5	M8x1	319,00
F63.H12	HSK-F 63	12	100	32	50	47	10	45,5	5	M8x1	319,00
F63.H14	HSK-F 63	14	100	34	50	47	10	44	5	M10x1	319,00
F63.H16	HSK-F 63	16	100	38	50	52	10	44	5	M12x1	319,00
F63.H18	HSK-F 63	18	100	40	50	52	10	42	5	M12x1	319,00
F63.H20	HSK-F 63	20	100	42	50	52	10	42	5	M12x1	319,00
F63.H25	HSK-F 63	25	120	50	50	58	10	26	6	M12x1	339,00
F63.H32	HSK-F 63	32	125	60	50	62	10	26	6	M12x1	339,00

LSCX = Einspannlänge, max.      ADJRGA = Verstellweg, max.  
LSCX = Clamping depth, max.      ADJRGA = Length adjustment range, max.  
LSCX = Profondeur d'insertion, max.      ADJRGA = Course de réglage, max.

Lieferumfang: Ohne Spannschlüssel  
Delivery: Without wrench  
Livraison: Sans clé de serrage



**Spannkraft-Prüfgerät für Hydrodehnspannfutter - Seite 12.61**  
Clamping force proofing instrument for hydraulic chucks - page 12.61  
Appareil de contrôle des forces de serrage pour mandrin expansibles hydrauliques - page 12.61



## Reparatur und Wartung für Hydro-Dehnspannfutter

Die Hydro-Dehnspanntechnik ist eine weltweit verbreitete, bewährte und zuverlässige Methode zur Aufnahme von Werkzeugen. Dank ihrer konstruktiven Vorteile ist sie unempfindlich, wartungsarm und langlebig. Dennoch kommt es durch thermische und mechanische Belastung im Werkstattgebrauch im Laufe der Zeit zu Spannkraftverlusten. Die Folge sind schlechtere Werkzeugstandzeiten und Qualitätseinbußen bei der Bearbeitung bis hin zum teuren Werkzeugbruch.

Wir warten und reparieren Ihre Hydro-Dehnspannfutter - egal ob von uns oder ein Fremdfabrikat - kostengünstig hier bei uns in Süd-Deutschland.

Hier prüfen wir die Ursachen für den Spannkraftverlust und reparieren innerhalb von zwei Wochen zu einem günstigen Festpreis. Wir erneuern dabei alle Verschleißteile, befüllen das Hydrauliksystem neu und justieren das Hydrauliksystem auf den korrekten Spanndruck. Abschließend erfolgt eine Endprüfung.

Kontaktieren Sie unseren Kundenservice für weitere Informationen und Preise.

## Maintenance and repair of hydraulic chucks

*Clamping of tools with hydraulic chucks is a widespread, well-established and reliable method. It is a resistant, easy-to-operate and durable way of clamping due to its advantageous construction design. Nevertheless in the course of time under the influence of thermal and mechanical outputs at factories loss of clamping force is observed. As a result the life of the tool shortens and its quality during the working process reduces. Therefore it leads to a costly damage of the tool.*

*We maintain and repair your hydraulic chucks - both those manufactured at our place and those produced somewhere else - for a reasonable price here at our office in the south of Germany.*

*We check possible causes of the clamping force reduction and repair it within two weeks at a fixed low price. At the same time we renew all the fast wearing parts, fill the hydraulic system anew and adjust its clamping force. Afterwards the final inspection stage takes place.*

*You are welcome to contact our customer service for further information and prices.*

5

## La réparation et la maintenance des mandrins hydrauliques

L'accueil des outils à l'aide d'un mandrin hydraulique est une technique éprouvée, répandue à l'échelle mondiale et de confiance. Grâce à sa construction avantageuse elle est robuste, facile à entretenir et durable. Pourtant à cause de la charge thermique et mécanique imposés sur les mandrins lors du travail la tension du ressort diminue au fil du temps. Par conséquent la résistance des outils coupants se détériore et la qualité lors d'usinage se réduit. En retour cela conduit à la rupture coûteuse d'outil.

On entretient et répare vos mandrins hydrauliques - peu importe l'issue de notre production ou d'ailleurs - bon marché et ici chez nous au sud de l'Allemagne.

Tout d'abord nos spécialistes cherchent la cause de la perte de la tension du ressort, ensuite ils effectuent la réparation sous 2 semaines pour le prix fixe et favorable. En outre ils renouvellent toutes les pièces d'usure, remplissent le système hydraulique à nouveau et ajustent la tension correcte. À la fin l'inspection finale se déroule.

Contactez notre centre de service client pour obtenir l'information supplémentaire ainsi que l'information actuelle sur le prix.





## **Werkzeugaufnahmen ISO-12164-3 (HSK-T)**

***Toolholders  
ISO-12164-3 (HSK-T)***

**Porte-outils  
ISO-12164-3 (HSK-T)**

**DISCOUNT 20%**  
**DIN ISO 104-3 HSK-T**

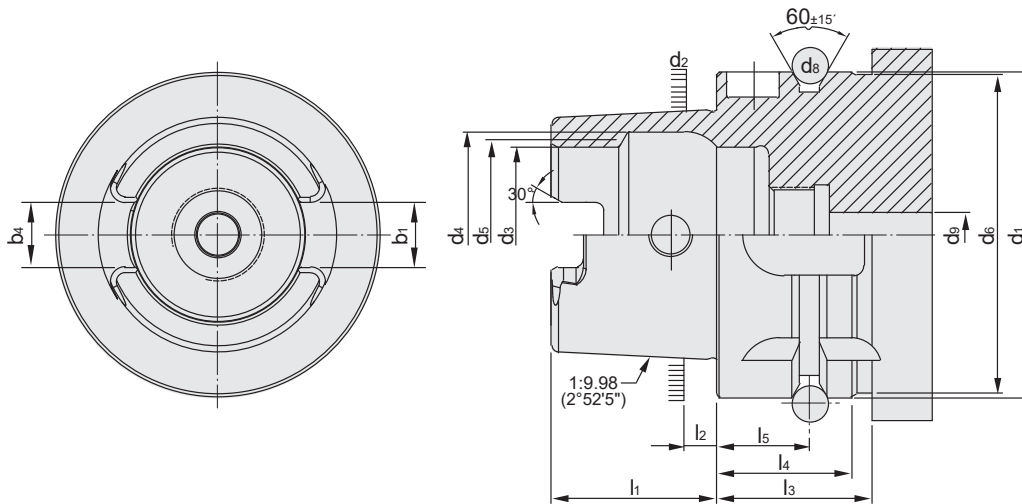

**5**

HSK	d <sub>1</sub> h10	d <sub>2</sub> H10	d <sub>3</sub> H11	d <sub>4</sub> H11	d <sub>5</sub> max	d <sub>6</sub> max	d <sub>8</sub> max	d <sub>9</sub> max	l <sub>1</sub> 0 -0,2	l <sub>2</sub> min	l <sub>3</sub> min	l <sub>4</sub> 0 -0,1	l <sub>5</sub> ±0,1	b <sub>1</sub> ±0,04	b <sub>2</sub> H10	b <sub>4</sub> +0,03 0
32	32	24,007	17	20,5	19	31	4	4,2	16	3,2	23	20	16	7,05	7	9
40	40	30,007	21	25,5	23	39	4	5	20	4	23	20	16	8,05	9	11
50	50	38,009	26	32	29	49	7	6,8	25	5	30	26	18	10,54	12	14
63	63	48,010	34	40	37	62	7	8,4	32	6,3	30	26	18	12,54	16	18
80	80	60,012	42	50	46	79	7	10,2	40	8	30	26	18	16,04	18	20
100	100	75,013	53	63	58	99	7	12	50	10	34	29	20	20,02	20	22

**Werkstoff:** Legierter Einsatzstahl mit einer Zugfestigkeit im Kern von min. 1000 N / mm<sup>2</sup>. Einsatzgehärtet HRC 60 ± 2 (HV 700 ± 50), Härtetiefe 0,8 mm ± 0,2 mm, brüniert und präzisionsgeschliffen.

**Material:** Alloyed case-hardened steel, tensile core strength of min. 1000 N / mm<sup>2</sup>. Case hardened HRC 60 ± 2 (HV 700 ± 50), hardening depth 0.8 mm ± 0.2 mm, black-finished and precisely grinded.

**Matière:** Acier de cémentation allié. Résistance à la traction dans le noyau de min 1000 N / mm<sup>2</sup>. Cémentation à HRC 60 ± 2 (HV 700 ± 50), profondeur de cémentation 0,8 mm ± 0,2 mm, bruni et rectifié précisément.

Die HSK-T (T = Turning) Norm wurde speziell für den Einsatz von stehenden Werkzeugen auf Drehmaschinen entwickelt. Im Vergleich zu den anderen HSK-Varianten ist das Mitnehmerspiel eingeschränkt und der Einfluss auf die Position der Schneide minimiert. Zusätzlich wird es möglich, ohne Umbauten am Revolver vorzunehmen, auch angetriebene Werkzeuge auf dem HSK-T Platz aufzunehmen.

*The HSK-T (T = Turning) standard was specially developed for the use of stationary tools on lathes. Compared to the other HSK variants, the driver play is restricted and the influence on the position of the cutting edge is minimised. In addition, it is possible to accommodate driven tools on the HSK-T space without having to make any modifications to the turret.*

La norme HSK-T (T = Turning) a été spécialement développée pour l'utilisation d'outils à l'arrêt sur les tours. Par rapport aux autres variantes HSK, le jeu d'entraînement est limité et l'influence sur la position de l'arête de coupe est minimisée. De plus, il devient possible d'accueillir des outils entraînés sur l'emplacement HSK-T sans devoir procéder à des modifications sur la tourelle.

**Normative Verweise:**

ISO 12164-3:2014-12 [AKTUELL]  
Hohlkegelschnittstelle mit Plananlage -  
Teil 3: Maße von Schäften für stehende Werkzeuge

**Normative references:**

ISO 12164-3:2014-12 [CURRENT]  
Hollow taper interface with face contact -  
Part 3: Dimensions of shanks for stationary tools

**Références normatives:**

ISO 12164-3:2014-12 [À JOUR]  
Interface de cône creux avec installation plane -  
Partie 3 : Dimensions des queues d'outils verticaux



Index  
Sommaire

5.87	5.88	5.89	5.90
5.91	5.92	5.93	5.94
5.95	5.96	5.97	5.98
5.99	5.100	5.101	





**Verwendung:**

Zur Aufnahme von allen nach DIN 6595 genormten Vollbohrern mit Zylinderschaft.

**Application:**

For mounting solid drills with cylindrical shank according to DIN 6595.

**Application:**

Pour le serrage de forets à queue cylindrique suivant DIN 6595.

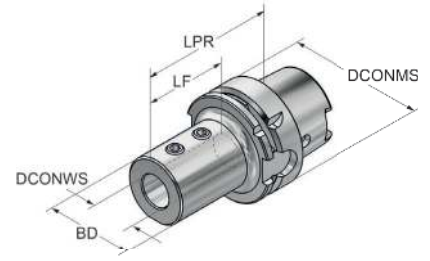

ISO 12164-3	Form T	RFID Chip
----------------	-----------	--------------

5

Bestell-Nr. Order no. Référence	HSK	DCONMS	DCONWS	BD	LF	LPR	TDCON	EUR
T63.51.16.80	HSK-T 63	63	16	34	54	80	H6	258,00
T63.51.20.80	HSK-T 63	63	20	40	54	80	H6	258,00
T63.51.25.85	HSK-T 63	63	25	45	59	85	H6	258,00
T63.51.32.90	HSK-T 63	63	32	52	63	90	H6	258,00
T63.51.40.100	HSK-T 63	63	40	60	73	100	H6	258,00

**Hinweis:** Plangeschliffene Anlagefläche  
**Note:** Contact surface precision grinded  
**Observation:** Surface de montage rectifié précisément

**Lieferumfang:** Mit Spannschrauben, ohne die abgebildeten Schneidwerkzeuge  
**Delivery:** With clamping screws, without the illustrated cutting tools  
**Livraison:** Avec vis de serrage, sans les outils de coupe illustrés



HSK-T holders for insert drills

HSK-T Porte-foret pour forets à plaquettes amovibles



**Verwendung:**  
Für Innenbearbeitung mit Bohrstängen.

**Application:**  
For internal machining with boring bars.

**Application:**  
Pour l'usinage intérieur avec barres d'alésage.

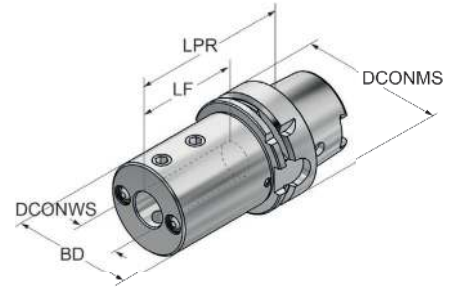

Bestell-Nr. Order no. Référence	HSK	DCONMS	DCONWS	BD	LF	LPR	TDCON	EUR
T63.52.06.90	HSK-T 63	63	6	38	55	90	H6	308,00
T63.52.08.90	HSK-T 63	63	8	40	55	90	H6	308,00
T63.52.10.90	HSK-T 63	63	10	42	55	90	H6	308,00
T63.52.12.90	HSK-T 63	63	12	44	55	90	H6	308,00
T63.52.16.90	HSK-T 63	63	16	48	65	90	H6	308,00
T63.52.20.90	HSK-T 63	63	20	52	65	90	H6	308,00
T63.52.25.90	HSK-T 63	63	25	57	65	90	H6	308,00
T63.52.32.90	HSK-T 63	63	32	64	65	90	H6	308,00
T63.52.40.100	HSK-T 63	63	40	74	75	100	H6	336,00

5

**Ausführung:** Spannmöglichkeit beidseitig. Mit einstellbaren Kugelspritzdüsen, verschließbar für Werkzeuge mit innerer Kühlmittelzufuhr  
**Version:** Clamping possible on both sides, with adjustable ball spray nozzles, closable for tools with internal coolant supply  
**Version:** Possibilité de serrage des deux côté. Avec buses d'injection à billes réglables, obturables pour les outils avec arrosage interne

**Lieferumfang:** Mit Spannschrauben, ohne die abgebildeten Schneidwerkzeuge  
**Delivery:** With clamping screws, without the illustrated cutting tools  
**Livraison:** Avec vis de serrage, sans les outils de coupe illustrés





## HSK-T (ISO 12164-3) auf PSK (ISO 26623-1)

Reducing adapter for adaption from HSK-T to PSC (ISO 12164-3 to ISO 26623-1)

Douille de réduction pour adaptation de HSK-T à PSC (ISO 12164-3 à ISO 26623-1)



**Verwendung:**

Zur Adaption von HSK-T auf PSK (ISO 12164 auf ISO 26623-1)

**Application:**

For adaption from HSK-T to PSK (ISO 12164 to ISO 26623-1)

**Application:**

Pour adaptation de HSK-T à PSK (ISO 12164 à ISO 26623-1).

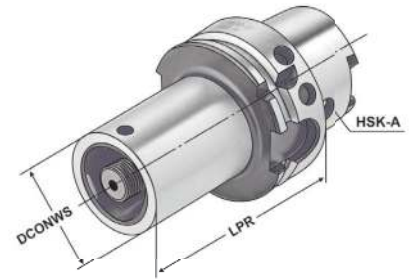

ISO 12164-3

Form T

RFID Chip

ISO 26623

5

Bestell-Nr. Order no. Référence	HSK	Typ	DCONWS	LPR	TQX	THID	EUR
T63.09.C3.075	HSK-T 63	PSK C3	32	75	45	M12x1,5	410,00
T63.09.C4.080	HSK-T 63	PSK C4	40	80	55	M14x1,5	410,00
T63.09.C5.090	HSK-T 63	PSK C5	50	90	95	M16x1,5	410,00
T63.09.C6.110	HSK-T 63	PSK C6	63	110	170	M20x2,0	410,00

**Ausführung:**

Adapter HSK / PSK mit Axialspannung. Innen und außen geschliffen. Das im PSK-Werkzeughalter für Kühlmittel-Rohre vorgesehene Innengewinde wird mit der im Adapter integrierten Zylinderkopfschraube verschraubt. Spannschraube durchbohrt, somit ist das System für Innenkühlung geeignet.

Passend für Werkzeugaufnahmen mit Polygonschaft (PSC/PSK) ISO 26623-1.

**Version:**

Adapters HSK / PSK with axial clamping. Ground internally and externally. The internal thread provided for the coolant tube in the PSC toolholder is plugged with the socket-head screw incorporated in the adapter. The clamping screw incorporates a through hole, so the system is suitable for through-coolant feed.

Suitable for tool arbor with polygonal shank (PSC) - ISO 26623-1.

**Exécution:**

Adaptateurs HSK / PSK Tension axiale. Intérieur et extérieur rectifiés. Le filetage intérieur prévu pour les conduits d'arrosage dans le porte-outils PSC est vissé à l'aide de la vis à tête cylindrique intégrée dans l'adaptateur. Système adapté à l'arrosage interne grâce à la vis de serrage percée. Pour la réception d'outils PSK ISO 26623-1.

**Lieferumfang:** Mit Spannschraube  
**Delivery:** Clamping screw  
**Livraison:** Avec vis de serrage



Boring bar blanks  
Barres d'alésage



**Verwendung:**  
Zur Herstellung von Sonderwerkzeugen.

**Application:**  
*For the manufacturing of special tools.*

**Application:**  
Pour la fabrication d'outils spéciaux.

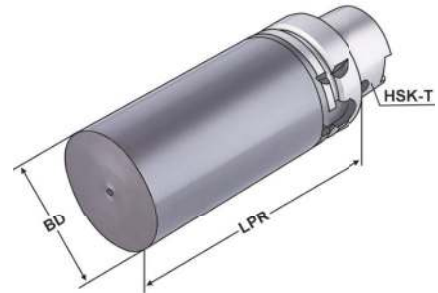

ISO  
12164-3

Form  
T

RFID  
Chip

Bestell-Nr. Order no. Référence	HSK	BD	LPR	EUR
T63.17.63.140	HSK-T 63	63	140	123,00
T63.17.80.200	HSK-T 63	80	200	141,00

5

**Ausführung:** Kegel und Bund gehärtet und geschliffen. Schaft weich zur weiteren Bearbeitung.  
**Version:** *Cone and flange hardened and grinded. Soft body for later processing.*  
**Version:** Cône et collerette durcis et rectifiés. Corps doux pour un usinage ultérieur.



5.51



10.77



HSK-T multi-turning-toolholders with internal coolant supply  
Porte-outils multi-tournants HSK-T avec arrosage interne



**Verwendung:**  
Drehhalter für Klemmhalter mit Kühlmittelzufuhr direkt zur Schneide und für ISO-Klemmhalter mit Pratzenklemmung zur optimalen Kühlung der Schneide

**Application:**  
Rotary holder for clamp holders with coolant supply directly to the cutting edge and for ISO clamp holders with claw clamping for optimum cooling of the cutting edge

**Application:**  
Porte-plaquettes rotatif pour porte-plaquettes avec arrosage direct de la lame et pour porte-plaquettes ISO avec serrage par griffe pour un refroidissement optimal de la lame

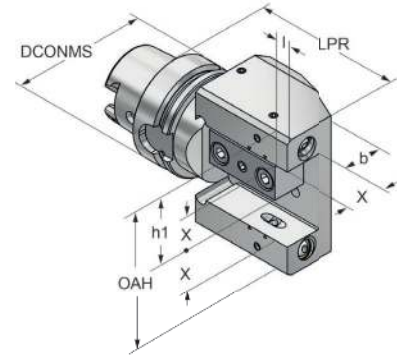

ISO 12164-3	Form T	RFID Chip
----------------	-----------	--------------

5

Bestell-Nr. Order no. Référence	HSK	DCONMS	LPR	X	OAH	h1	b	l	EUR
T63.81.20.112	HSK-T 63	63	112	20	80	40	31,5	10	499,00
T63.81.25.112	HSK-T 63	63	112	25	90	45	31,5	10	538,00

**Hinweis:** Kühlmitteldruck bis 100 bar  
**Note:** Coolant pressure up to 100 bar  
**Observation:** Pression du liquide de refroidissement jusqu'à 100 bar

**Ausführung:**  
Ein Drehhalter - vier Einsatzmöglichkeiten:  
Links - rechts - vorkopf - überkopf.  
Spritzdüsen verschließbar für Werkzeuge mit innerer Kühlmittelzufuhr.

**Version:**  
One turning toolholder - four possibilities:  
Left - right - forehead - overhead.  
Coolant nozzles lockable for tools with internal coolant.

**Exécution:**  
Un mandrin tournant - quatre possibilités d'utilisation:  
Gauche - droite - front - au-dessus de la tête.  
Gicleurs verrouillables pour outils avec arrosage interne.



**Lieferumfang:** Ohne die abgebildeten Schneidwerkzeuge  
**Delivery:** Without the illustrated cutting tools  
**Livraison:** Sans les outils de coupe illustrés



HSK-T multi-turning-toolholders 90° with internal coolant supply  
 Porte-outils multi-tournants HSK-T 90° avec arrosage interne



**Verwendung:**

Drehhalter für Klemmhalter mit Kühlmittelzufuhr direkt zur Schneide und für ISO-Klemmhalter mit Pratzenklammerung zur optimalen Kühlung der Schneide

**Application:**

Rotary holder for clamp holders with coolant supply directly to the cutting edge and for ISO clamp holders with claw clamping for optimum cooling of the cutting edge

**Application:**

Porte-plaquettes rotatif pour porte-plaquettes avec arrosage direct de la lame et pour porte-plaquettes ISO avec serrage par griffe pour un refroidissement optimal de la lame

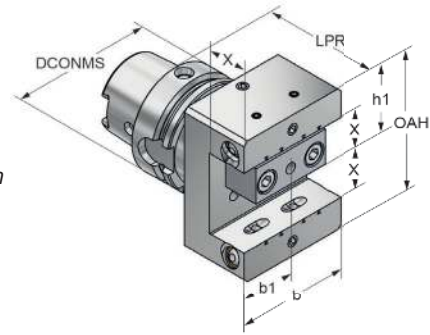

Bestell-Nr. Order no. Référence	HSK	DCONMS	LPR	X	OAH	h1	b	b1	EUR
T63.82.20.85	HSK-T 63	63	85	20	80	40	35	70	499,00
T63.82.25.85	HSK-T 63	63	85	25	90	45	35	70	538,00

5

**Hinweis:** Kühlmitteldruck bis 100 bar  
**Note:** Coolant pressure up to 100 bar  
**Observation:** Pression du liquide de refroidissement jusqu'à 100 bar

**Ausführung:**  
 Ein Drehhalter - vier Einsatzmöglichkeiten:  
 Links - rechts - vorkopf - überkopf.  
 Spritzdüsen verschleißbar für Werkzeuge mit innerer Kühlmittelzufuhr.

**Version:**  
 One turning toolholder - four possibilities:  
 Left - right - forehead - overhead.  
 Coolant nozzles lockable for tools with internal coolant.

**Exécution:**  
 Un mandrin tournant - quatre possibilités d'utilisation:  
 Gauche - droite - front - au-dessus de la tête.  
 Gicleurs verrouillables pour outils avec arrosage interne.



**Lieferumfang:** Ohne die abgebildeten Schneidwerkzeuge  
**Delivery:** Without the illustrated cutting tools  
**Livraison:** Sans les outils de coupe illustrés





HSK-T multi-turning-toolholders 45° with...  
Porte-outils multi-tournants HSK-T 45° avec arrosage interne



**Verwendung:**  
Drehhalter für Klemmhalter mit Kühlmittelzufuhr direkt zur Schneide und für ISO-Klemmhalter mit Prätzenklammung zur optimalen Kühlung der Schneide

**Application:**  
Rotary holder for clamp holders with coolant supply directly to the cutting edge and for ISO clamp holders with claw clamping for optimum cooling of the cutting edge

**Application:**  
Porte-plaquettes rotatif pour porte-plaquettes avec arrosage direct de la lame et pour porte-plaquettes ISO avec serrage par griffe pour un refroidissement optimal de la lame

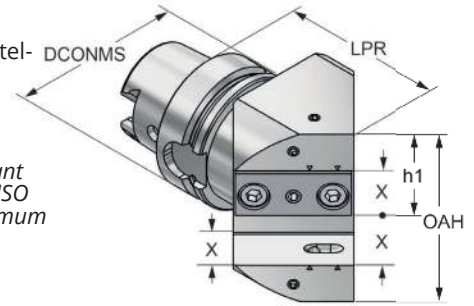

ISO 12164-3	Form T	RFID Chip
----------------	-----------	--------------

5

Bestell-Nr. Order no. Référence	HSK	DCONMS	LPR	X	OAH	h1	EUR
T63.83.20.93	HSK-T 63	63	93	20	80	40	507,00
T63.83.25.97	HSK-T 63	63	97	25	90	45	546,00

**Hinweis:** Kühlmitteldruck bis 100 bar  
**Note:** Coolant pressure up to 100 bar  
**Observation:** Pression du liquide de refroidissement jusqu'à 100 bar



**Lieferumfang:** Ohne die abgebildeten Schneidwerkzeuge  
**Delivery:** Without the illustrated cutting tools  
**Livraison:** Sans les outils de coupe illustrés



*HSK-T infeed-toolholders with internal coolant*  
 HSK-T Porte-outils de tronçonnage avec refroidissement interne



**Verwendung:**  
 Für Abstechhalter mit Kühlmittelzufuhr direkt zur Schneide. Spritzdüse verschließbar.

**Application:**  
 For parting-off holders with coolant supply directly to the cutting edge. Spray nozzle can be closed.

**Application:**  
 Pour porte-outils de tronçonnage avec arrosage direct de la lame. Buse d'injection obturable.

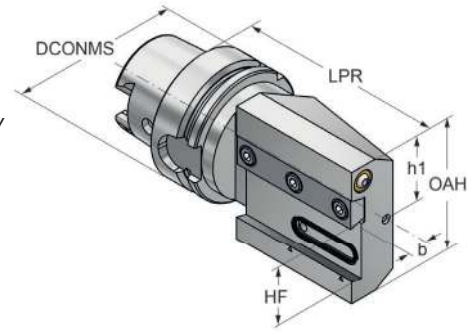

ISO 12164-3	Form T	RFID Chip
----------------	-----------	--------------

Bestell-Nr. Order no. Référence	HSK	DCONMS	LPR	HF	OAH	b	h1	EUR
T63.65.32.112	HSK-T 63	63	112	32	70	15	35	504,00

5

**Hinweis:** Kühlmitteldruck bis 100 bar  
**Note:** Coolant pressure up to 100 bar  
**Observation:** Pression du liquide de refroidissement jusqu'à 100 bar

**Version 1**  
 Kühlmittelzufuhr mittels schwenkbarer Spritzdüse  
 Coolant supply by means of swivelling spray nozzle  
 Arrosage par buse pivotante

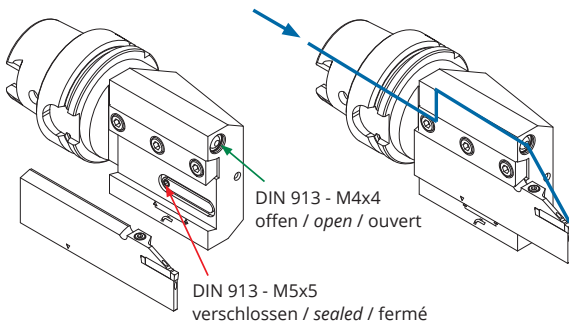

**Version 2**  
 Kühlmittelzufuhr intern durch das Abstechschwert  
 Coolant supply internally through the cut-off sword  
 Arrosage interne par la lame de tronçonnage

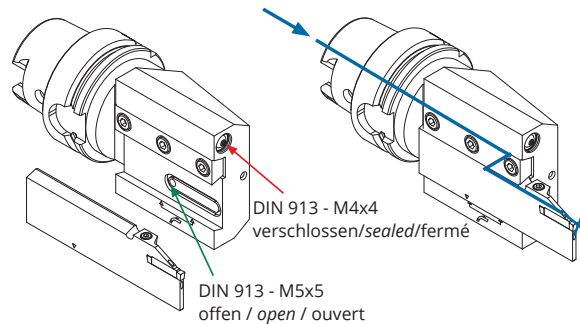

**Lieferumfang:** Ohne die abgebildeten Schneidwerkzeuge  
**Delivery:** Without the illustrated cutting tools  
**Livraison:** Sans les outils de coupe illustrés





HSK-T single turning toolholder with internal coolant  
Porte-outil de tournage simple HSK-T avec arrosage interne



**Verwendung:**  
für Klemmhalter mit Kühlmittelzufuhr  
direkt zur Schneide, Spritzdüse  
verschießbar

**Application:**  
for clamping holders with coolant channels  
directly to the cutting edge, Coolant nozzles  
lockable

**Application:**  
pour porte-outils avec arrosage direct de la  
lame, buse de pulvérisation obturable

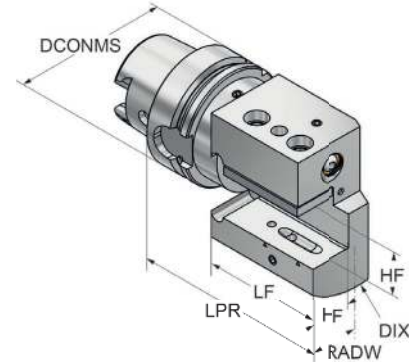

ISO 12164-3	Form T	RFID Chip
----------------	-----------	--------------

Bestell-Nr. Order no. Référence	HSK	DCONMS	LPR	X	DIX	LF	RADW	HF	EUR
T63.84.25.110	HSK-T 63	63	110	30	100	68	30	25	448,00

5

**Hinweis:** Kühlmitteldruck bis 100 bar  
**Note:** Coolant pressure up to 100 bar  
**Observation:** Pression du liquide de refroidissement jusqu'à 100 bar

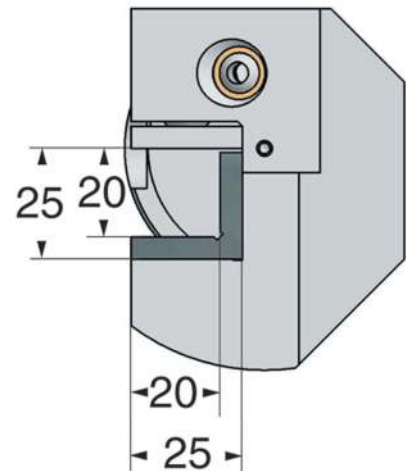
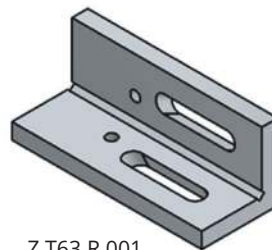
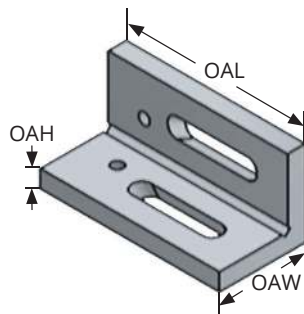

Bestell-Nr. Order no. Référence	OAH	OAL	OAW	EUR
Z.T63.R.001	5	60	24	70,00

**Lieferumfang:** Ohne die abgebildeten Schneidwerkzeuge, ohne Reduzierung  
**Delivery:** Without the illustrated cutting tools, without reduction  
**Livraison:** Sans les outils de coupe illustrés, sans réduction

HSK-T single turning toolholder with internal coolant  
 Porte-outil de tournage simple HSK-T avec arrosage interne



**Verwendung:**  
 für Klemmhalter mit Kühlmittelzufuhr  
 direkt zur Schneide, Spritzdüse  
 verschließbar

**Application:**  
 for clamping holders with coolant channels  
 directly to the cutting edge, Coolant nozzles  
 lockable

**Application:**  
 pour porte-outils avec arrosage direct de la  
 lame, buse de pulvérisation obturable

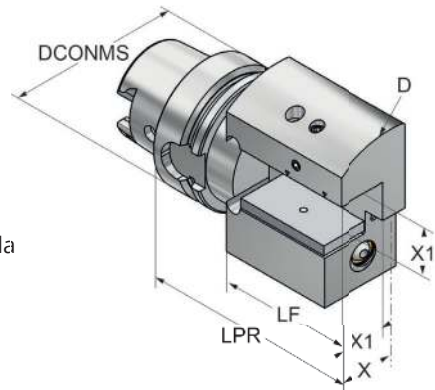

ISO 12164-3	Form T	RFID Chip
----------------	-----------	--------------

Bestell-Nr. Order no. Référence	HSK	DCONMS	LPR	X	X1	LF	D	EUR
T63.85.25.110	HSK-T 63	63	110	30	25	68	100	448,00

5

**Hinweis:** Kühlmitteldruck bis 100 bar  
**Note:** Coolant pressure up to 100 bar  
**Observation:** Pression du liquide de refroidissement jusqu'à 100 bar

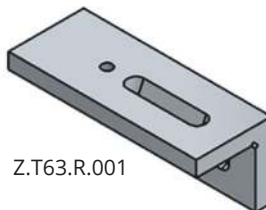
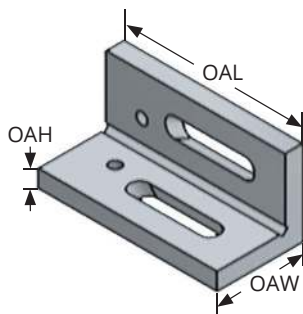

Z.T63.R.001

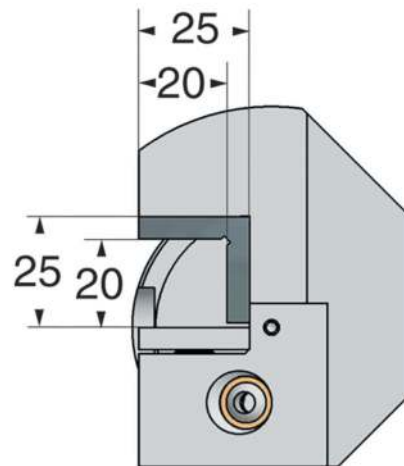

Bestell-Nr. Order no. Référence	OAH	OAL	OAW	EUR
Z.T63.R.001	5	60	24	70,00

**Lieferumfang:** Ohne die abgebildeten Schneidwerkzeuge, ohne Reduzierung  
**Delivery:** Without the illustrated cutting tools, without reduction  
**Livraison:** Sans les outils de coupe illustrés, sans réduction





HSK-T double turning toolholder with...  
Porte-outils de tournage double HSK-T avec arrosage interne



**Verwendung:**  
für Klemmhalter mit Kühlmittelzufuhr  
direkt zur Schneide, Spritzdüse  
verschießbar

**Application:**  
for clamping holders with coolant channels  
directly to the cutting edge, Coolant nozzles  
lockable

**Application:**  
pour porte-outils avec arrosage direct de  
la lame, buse de pulvérisation obturable

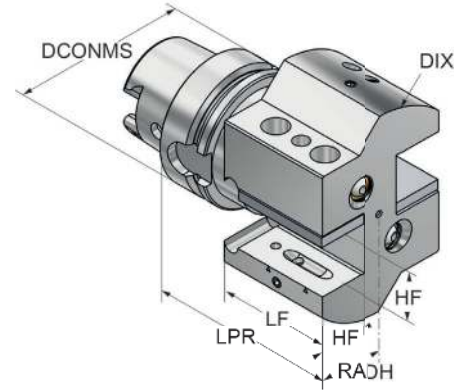

ISO 12164-3	Form T	RFID Chip
----------------	-----------	--------------

5

Bestell-Nr. Order no. Référence	HSK	DCONMS	DIX	LPR	LF	RADH	HF	EUR
T63.87.25.100	HSK-T 63	63	100	100	58	35	25	538,00

**Hinweis:** Kühlmitteldruck bis 100 bar  
**Note:** Coolant pressure up to 100 bar  
**Observation:** Pression du liquide de refroidissement jusqu'à 100 bar

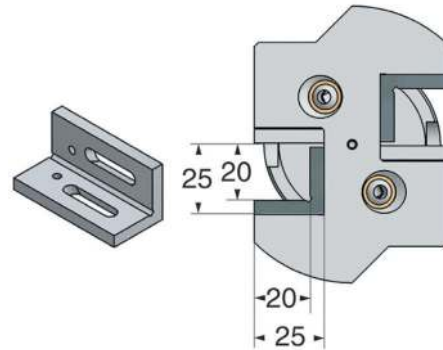
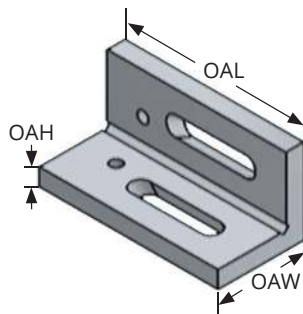

Bestell-Nr. Order no. Référence	OAH	OAL	OAW	EUR
Z.T63.R.002	5	50	24	70,00

**Lieferumfang:** Ohne die abgebildeten Schneidwerkzeuge, ohne Reduzierung  
**Delivery:** Without the illustrated cutting tools, without reduction  
**Livraison:** Sans les outils de coupe illustrés, sans réduction

HSK-T double turning toolholder with internal coolant supply  
Porte-outils de tournage double HSK-T avec arrosage interne



**Verwendung:**  
für Klemmhalter mit Kühlmittelzufuhr  
direkt zur Schneide, Spritzdüse  
verschließbar

**Application:**  
for clamping holders with coolant channels  
directly to the cutting edge, Coolant nozzles  
lockable

**Application:**  
pour porte-outils avec arrosage direct de  
la lame, buse de pulvérisation obturable

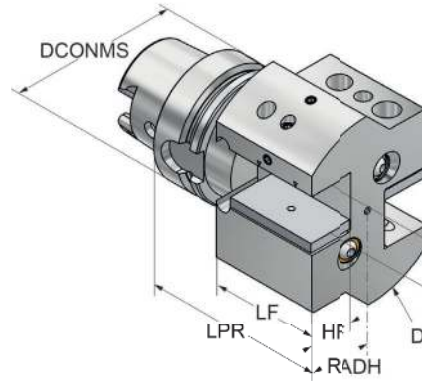

Bestell-Nr. Order no. Référence	HSK	DCONMS	DIX	LPR	LF	RADH	HF	EUR
T63.88.25.100	HSK-T 63	63	100	100	58	35	25	538,00

5

**Hinweis:** Kühlmitteldruck bis 100 bar  
**Note:** Coolant pressure up to 100 bar  
**Observation:** Pression du liquide de refroidissement jusqu'à 100 bar

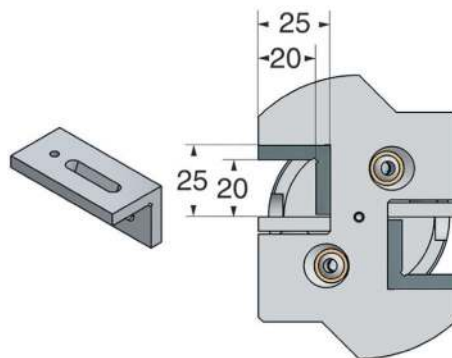
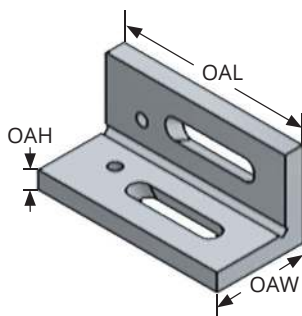

Bestell-Nr. Order no. Référence	OAH	OAL	OAW	EUR
Z.T63.R.002	5	50	24	70,00

**Lieferumfang:** Ohne die abgebildeten Schneidwerkzeuge, ohne Reduzierung  
**Delivery:** Without the illustrated cutting tools, without reduction  
**Livraison:** Sans les outils de coupe illustrés, sans réduction



HSK-T triple turning toolholder with internal cooling  
HSK-T Support rotatif triple avec refroidissement interne



**Verwendung:**  
für Klemmhalter mit Kühlmittelzufuhr  
direkt zur Schneide, Spritzdüse  
verschießbar

**Application:**  
for clamping holders with coolant channels  
directly to the cutting edge, Coolant nozzles  
lockable

**Application:**  
pour porte-outils avec arrosage direct de la  
lame, buse de pulvérisation obturable

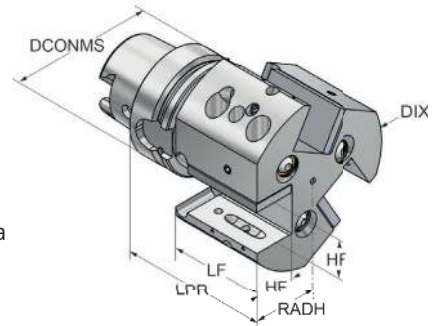

ISO 12164-3	Form T	RFID Chip
----------------	-----------	--------------

5

Bestell-Nr. Order no. Référence	HSK	DCONMS	DIX	LPR	LF	RADH	HF	EUR
T63.75.25.100	HSK-T 63	63	100	100	58	40	25	605,00

**Hinweis:** Kühlmitteldruck bis 100 bar  
**Note:** Coolant pressure up to 100 bar  
**Observation:** Pression du liquide de refroidissement jusqu'à 100 bar

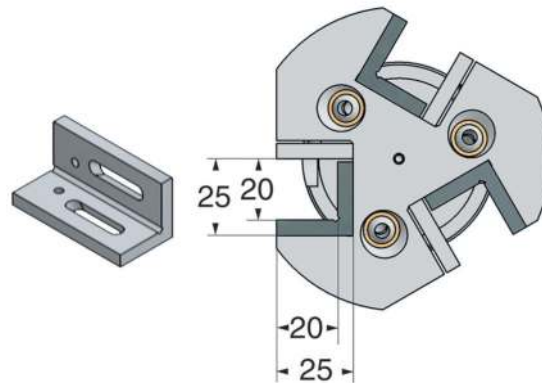
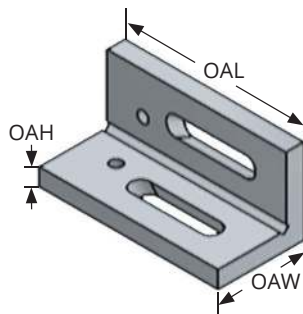

Bestell-Nr. Order no. Référence	OAH	OAL	OAW	EUR
Z.T63.R.002	5	50	24	70,00

**Lieferumfang:** Ohne die abgebildeten Schneidwerkzeuge, ohne Reduzierung  
**Delivery:** Without the illustrated cutting tools, without reduction  
**Livraison:** Sans les outils de coupe illustrés, sans réduction

HSK-T triple turning toolholder with internal cooling  
 HSK-T Support rotatif triple avec refroidissement interne



**Verwendung:**  
 für Klemmhalter mit Kühlmittelzufuhr  
 direkt zur Schneide, Spritzdüse  
 verschließbar

**Application:**  
 for clamping holders with coolant channels  
 directly to the cutting edge, Coolant nozzles  
 lockable

**Application:**  
 pour porte-outils avec arrosage direct de la  
 lame, buse de pulvérisation obturable

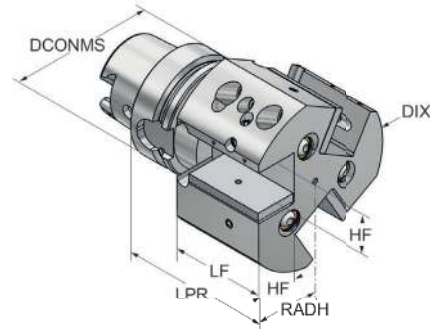

ISO 12164-3	Form T	RFID Chip
----------------	-----------	--------------

Bestell-Nr. Order no. Référence	HSK	DCONMS	DIX	LPR	LF	RADH	HF	EUR
T63.76.25.100	HSK-T 63	63	100	100	58	40	25	605,00

5

**Hinweis:** Kühlmitteldruck bis 100 bar  
**Note:** Coolant pressure up to 100 bar  
**Observation:** Pression du liquide de refroidissement jusqu'à 100 bar

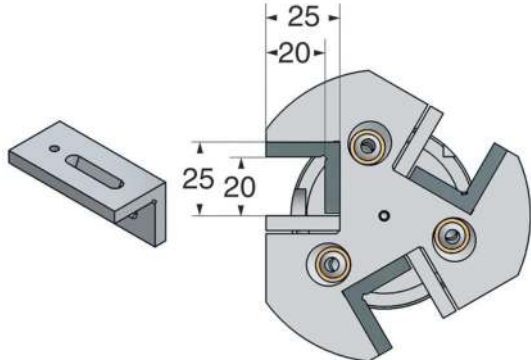
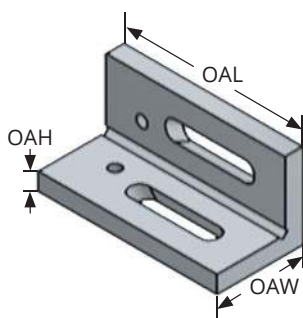

Bestell-Nr. Order no. Référence	OAH	OAL	OAW	EUR
Z.T63.R.002	5	50	24	70,00

**Lieferumfang:** Ohne die abgebildeten Schneidwerkzeuge, ohne Reduzierung  
**Delivery:** Without the illustrated cutting tools, without reduction  
**Livraison:** Sans les outils de coupe illustrés, sans réduction

Master Setting Gauge  
Outil d'alignement**Verwendung:**

Kalibrierung der Winkelposition von Spindeln von Fräs-Dreh-Zentren

**Application:***Calibration of the angular position of spindles of milling-turning centres***Application:**

Calibrage de la position angulaire des broches de centres de fraisage-tournage

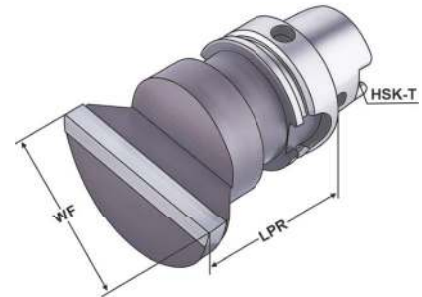
ISO  
12164-3Form  
TRFID  
ChipBestell-Nr.  
Order no.

Référence

HSK

LPR

WF

EUR

T63.18.90.090

HSK-T 63

90

90

408,00

5

**Verwendung:**

- Überprüfen und Einstellen der Drehwinkel-Position von Maschinenspindeln (M19 Funktion - Spindel-Halt in definierter Endstellung).
- Ermitteln der Referenz-Punkte (Kalibrieren) von optischen Voreinstellgeräten
- Kalibrierung der Winkelposition von Spindeln von Fräs-Dreh-Zentren
- Kalibrierung der Genauigkeit der Revolveraufnahmen von CNC-Drehmaschinen
- Einstellen des Drehtisch-Nullpunkts von 5-Achsen-Bearbeitungszentren

**Genauigkeit:**

- Ausrichtfläche  $\pm 0,01$ mm zur Mittelachse
- Parallelität zu Mitnehmernuten  $< 0,01$  mm

**Application:**

- *Checking and setting the rotation angle position of machine spindles (M19 function - spindle stop in defined end position).*
- *Determining the reference points (calibration) of optical presetting devices*
- *Calibration of the angular position of spindles of milling-turning centres*
- *Calibrating the accuracy of the turret recordings of CNC lathes*
- *Setting the rotary table zero point of 5-axis machining centres*

**Accuracy:**

- *Alignment surface  $\pm 0.01$ mm to the centre axis*
- *Parallelism to driver grooves  $< 0.01$  mm*

**Application:**

- Vérification et réglage de la position angulaire de rotation des broches de machines (fonction M19 - arrêt de la broche en position finale définie).
- Détermination des points de référence (étalonnage) des appareils de pré-réglage optiques.
- Calibrage de la position angulaire des broches de centres de fraisage-tournage
- Calibrage de la précision des tourelles de tours CNC.
- Réglage de l'origine de la table tournante de centres d'usinage à 5 axes.

**Précision:**

- Surface d'alignement  $\pm 0,01$ mm par rapport à l'axe central
- Parallélisme avec les rainures d'entraînement  $< 0,01$  mm

**Lieferumfang:** Auslieferung mit Prüfprotokoll  
**Delivery:** *Delivery with test certificate*  
**Livraison:** Livraison avec rapport d'essais

Multi-Task-Maschinen mit HSK-T-Spindel  
 Multi-task machines with HSK-T spindle  
 Machines multi-tâches avec broche HSK-T

Bearbeitungszentrum mit HSK-A-Spindel  
 Machining centre with HSK-A spindle  
 Centre d'usinage avec broche HSK-A

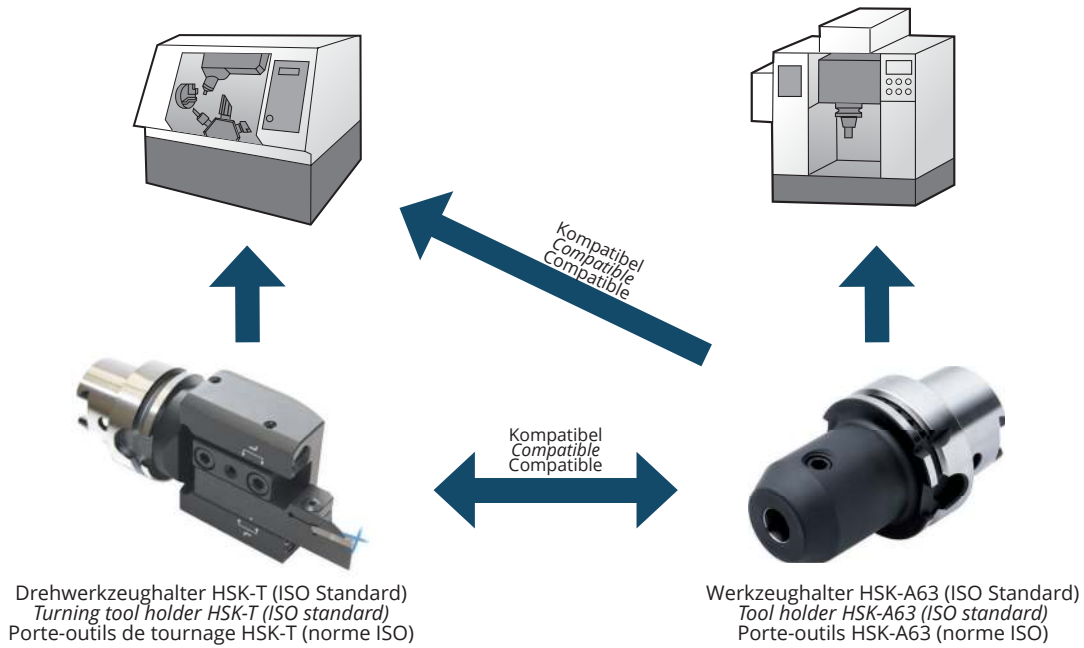

5

Verbesserte Toleranz der Mitnehmernut nach ICTM-Standard  
 Improved keyway tolerance according to ICTM standard  
 Tolérance améliorée de la rainure d'entraînement selon la norme ICTM

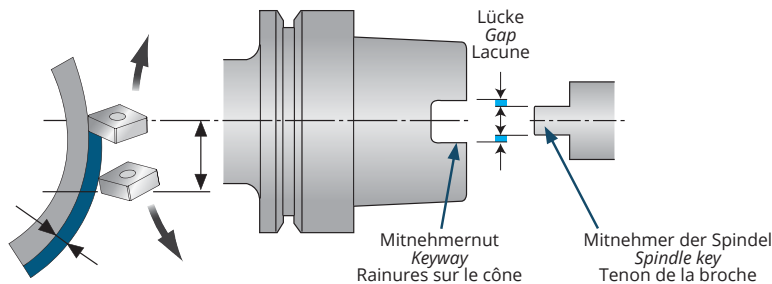
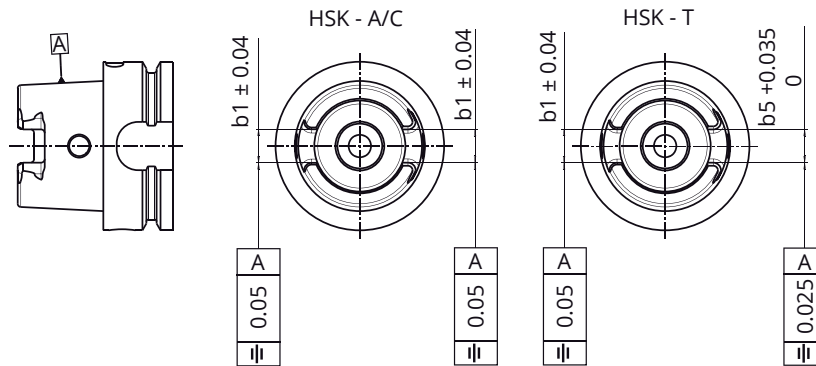

Der Spalt verursacht unterschiedliche Schnittdurchmesser. Beispiel bei Ø50.  
 HSK63T=3µm - HSK63A=14µm  
 The gap causes variant cutting diameters. Example at Ø50.  
 HSK63T=3µm - HSK63A=14µm  
 L'écart entraîne des diamètres de coupe différents. Exemple à Ø50.  
 HSK63T=3µm - HSK63A=14µm